Telemecanique Sensors

The essential guide of Detection



Simply easy!™

Telemecanique Sensors

Simply easy!™

Telemecanique brand has a 9 decades history manufacturing factory automation and safety sensors. Telemecanique wide ranges are most reliable and robust hence second to none on the market.

Our aim is to **simplify the life of our customers**, allowing them to concentrate on their core added value and machine performance.

This is why Telemecanique Sensors design and manufacture their products based on the following values:

- **Simplicity and modularity**
- **Easy to choose and select**
- **Easy to install and maintain**
- **Expert services to share our know-how**

Connect with the experts



- A dedicated Sales team: trained and experienced sales professionals are available to help you with any sensing application.
- Telemecanique Sensors team: are available for pre and post sales support. We become an extension of your team and we share our expertise with you.

www.tesensors.com

Detection

Limit switches, OsiSense XC	4 to 13
Detection by contact of rigid objects	
Sensors for pressure control, OsiSense XM, ZM	14 to 19
Detection by contact with fluid	
Inductive proximity sensors, OsiSense XS	20 to 30
Detection without contact of metal objects	
Capacitive proximity sensors, OsiSense XT	31
Detection of insulating materials or conductive materials	
Photo-electric sensors, OsiSense XU	32 to 43
Detection without contact of any object	
Ultrasonic sensors, OsiSense XX	44 to 46
Detection without contact of any object of any material	
Cabling system, OsiSense XZ	47
Pre-wired female connectors	
Rotary encoders, OsiSense XCC	48 and 49
Opto-electronic detection	
Radio frequency identification, OsiSense XG	50 and 51
13.56 MHz RFID detection	
Sensors for Safety, Preventa products	52 to 67
Sensors for explosive atmospheres, ATEX products	68 to 81

Telemecanique Sensors

Simply easy!™

• Safety switches



◀ **Preventa™ XUSL**, the new safety Light Curtains, for an efficient protection of machine operators, for finger, hand and body

Preventa™ XY2CJ, the emergency stop rope pull switches. A solution easy to reach and trigger from everywhere in the work zone ▶



• Pressure sensors



◀ Easily control machine pressure with the new **OsiSense™ XMLR**, the intuitive pressure switch that combines high performance and maximum ease of use.

OsiSense™ ZMLP, the simple switch with display that can be linked to a separate pressure transmitter, delivering a clear view of accurate pressure information even if the conduit runs in a hard to access location. ▶



• Radio Frequency Identification (RFID)



◀ **The OsiSense™ XG** identification system makes it possible to perform object traceability, identification (tracking) and access control functions.

The new Ethernet smart antenna **OsiSense™ XGCS850C201** enables up to 32 smart antennas to be daisy-chained.

• Photo Electric sensors



◀ **Osisense™ XUY** Roller Sensors, to be easily and fully integrated into your rollers conveyors system. New shape and easier fixation making it more adaptable for any case.

OsiSense™ XUK8T™ compact ▶ photo-electric laser sensor enabling reliable detection with high accuracy background suppression long distance, and for distance measurement, using "Time of Flight" (light velocity) (launch Q3 2014).



◀ **OsiSense™ XUVU**, the new ultrasonic Fork thru-beam for detection of transparent labels

OsiSense™ XUX9ARCNT16, a reliable ▶ photo electric sensor specially designed to detect proximity between two traveling overhead cranes "anti-collision". A strong red beam is highly visible on the reflector to allow easy and fast setting.



XCMD

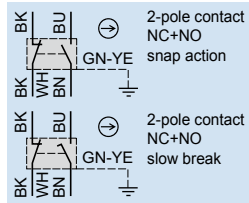

XCKT

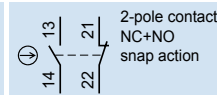

Miniature XCMD metal, pre-cabled; fixing by the body or by the head

Type of operator	Metal end plunger	Steel roller plunger	Thermoplastic roller lever	Steel roller lever	Variable length thermoplastic roller lever	M12 head metal end plunger
Mechanical durability (millions of operating cycles)	10	10	10	10	10	10
Actuation speed (in m/s)	0.5	0.5	1.5	1.5	1.5	0.5
Switches conforming to standard IEC 947-5-1 section 3	⊕	⊕	⊕	⊕	⊕	⊕
Product certification	CE - UL - CSA - CCC					
Degree of protection conforming to IEC 60529	IP 66 and IP 67					
Rated operational characteristics (conforming to EN IEC 60947-5-1)	AC-15; B300 (Ue = 240 V, Ie = 1.5 A) / DC-13; R300 (Ue = 250 V, Ie = 0.1 A)					
Fixing centres (mm)	20					M12 x 1
Body dimensions (mm) W x D x H	30 x 16 x 50					
Connection Cable	Pre-cabled, adjustable direction, length = 1 m (other lengths available on request)					
Complete switch 2-pole NC+NO snap action	XCMD2110L1	XCMD2102L1	XCMD2115L1	XCMD2116L1	XCMD2145L1	XCMD21F0L1
2-pole NC+NO break before make, slow break	XCMD2510L1	XCMD2502L1	XCMD2515L1	XCMD2516L1	XCMD2545L1	XCMD25F0L1
Connector	M12					
Complete switch NC+NO snap action (M12-5 pins)	XCMD2110C12	XCMD2102C12	XCMD2115C12	XCMD2116C12	XCMD2145C12	XCMD21F0C12
1C/O snap action (M12-4 pins) (1)	XCMD2110M12	XCMD2102M12	XCMD2115M12	XCMD2116M12	XCMD2145M12	XCMD21F0M12

(1) Although their design is identical to the pre-cabled switches, the switches incorporating an M12 4-pin connector cannot be marked with the symbol because they are single-pole C/O.

⊕ Positive opening operation.

XCKP/XCKD

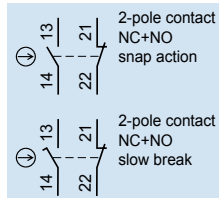

⊕ Positive opening operation.



Compact XCKD metal and XCKP plastic conforming to standard EN 50047

Type of operator	Metal end plunger	Steel roller plunger	Thermoplastic roller lever plunger, horizontal actuation in 1 direction	M18 head metal end plunger	M18 head steel roller plunger
Mechanical durability (millions of operating cycles)	15	10	15	10	10
Actuation speed (in m/s)	0.5	0.5	1	0.5	0.5
Switches conforming to standard IEC 947-5-1 section 3	⊕	⊕	⊕	⊕	⊕
Product certification	CE - CSA - CCC - GOST				
Degree of protection conforming to IEC 60529	IP 66 and IP 67				
Rated operational characteristics (conforming to EN IEC 60947-5-1)	AC-15; A300 (Ue = 240 V, Ie = 3 A) / DC-13; Q300 (Ue = 250 V, Ie = 0.27 A)				
Cable entry	1 tapped entry for ISO M16 x 1.5 cable gland (3) or M12 connector				
Fixing centres (mm)	20	20	20	M18 x 1	M18 x 1
Body dimensions (mm) W x D x H	31 x 30 x 65				
Metal switches					
Complete switch 2-pole NC+NO snap action	XCKD2110P16	XCKD2102P16	XCKD2121P16	XCKD21H0P16	XCKD21H2P16
2-pole NC+NO break before make, slow break	XCKD2510P16	XCKD2502P16	XCKD2521P16	XCKD25H0P16	XCKD25H2P16
2-pole NC+NO snap action (M12-5 pins)	XCKD2110M12	XCKD2102M12	XCKD2121M12	XCKD21H0M12	XCKD21H2M12
Plastic, double insulated switches					
Complete switch 2-pole NC+NO snap action	XCKP2110P16	XCKP2102P16	XCKP2121P16	XCKP21H0P16	XCKP21H2P16
2-pole NC+NO break before make, slow break	XCKP2510P16	XCKP2502P16	XCKP2521P16	XCKP25H0P16	XCKP25H2P16
2-pole NC+NO snap action (M12-4 pins)	XCKP2110M12	XCKP2102M12	XCKP2121M12	XCKP21H0M12	XCKP21H2M12

(3) For Pg 11 cable entries, replace P16 by G11. Example: XCKD2110P16 becomes XCKD2110G11.

For other cable entries, see customised assembly on page 7.

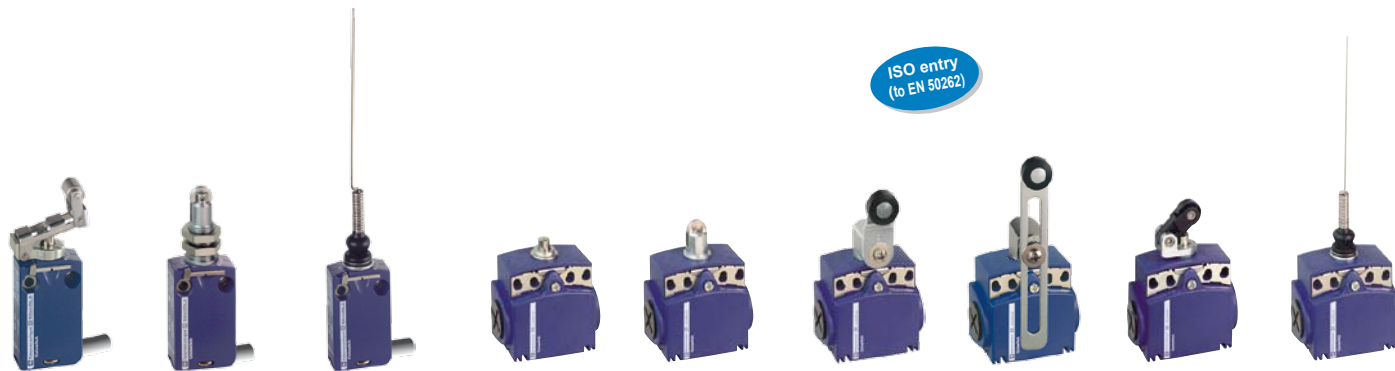

Compact XCKT plastic, 2 cable entries

Retractable steel roller lever plunger	M12 head steel roller plunger	"Cat's whisker"	Metal end plunger	Steel roller plunger	Thermoplastic roller lever	Variable length thermoplastic roller lever	Thermoplastic roller lever plunger, horizontal actuation in 1 direction	"Cat's whisker"
10	10	5	15	10	10	15	5	5
0,5	0.1	1	0.5	0.5	1.5	1	1	1
⊖	⊖	-	⊕	⊕	⊕	⊕	-	-
CE - CSA - CCC - GOST								
IP 66 and IP 67								
AC-15; A300 (Ue = 240 V, Ie = 3 A) / DC-13; Q300 (Ue = 250 V, Ie = 0.27 A)								
20	M12 x 1	20	20 or 40					
58 x 30 x 51								
2 tapped entries for ISO M16 x 1.5 cable gland (2)								
XCMD2124L1	XCMD21F2L1	XCMD2106L1	XCKT2110P16	XCKT2102P16	XCKT2118P16	XCKT2145P16	XCKT2121P16	XCKT2106P16
XCMD2524L1	XCMD25F2L1	XCMD2506L1	-	-	-	-	-	-
XCMD2124C12	XCMD21F2C12	XCMD2106C12	-	-	-	-	-	-
XCMD2124M12	XCMD21F2M12	XCMD2106M12	-	-	-	-	-	-

(2) For Pg 11 cable entries, replace P16 by G11. Example: XCKT2110P16 becomes XCKT2110G11.



Application - XCPR and XCDR with manual reset

Thermoplastic roller lever	Variable length Thermoplastic roller lever	Thermoplastic roller lever Ø 50 mm	"Cat's whisker"	Metal end plunger	Steel roller plunger	Thermoplastic roller lever plunger, horizontal actuation in 1 direction	Thermoplastic roller lever plunger, vertical actuation in 1 direction	Thermoplastic roller lever
10	10	10	5	1	1	1	1	1
1.5	1.5	1.5	1	0.5	0.5	1	1	1.5
⊖	⊖	⊖	-	⊕	⊕	⊕	⊕	⊕
CE - CSA - CCC - GOST								
IP 66 and IP 67								
AC-15; A300 (Ue = 240 V, Ie = 3 A) / DC-13; Q300 (Ue = 250 V, Ie = 0.27 A)								
1 tapped entry for ISO M20 x 1.5 cable gland (4)								
20	20	20	20	20	20	20	20	20
31 x 30 x 95								
XCKD2118P16	XCKD2145P16	XCKD2139P16	XCKD2106P16	XCDR2110P20	XCDR2102P20	XCDR2121P20	XCDR2127P20	XCDR2118P20
XCKD2518P16	XCKD2545P16	XCKD2539P16	XCKD2506P16	XCDR2510P20	XCDR2502P20	XCDR2521P20	XCDR2527P20	XCDR2518P20
XCKD2118M12	XCKD2145M12	XCKD2139M12	XCKD2106M12	-	-	-	-	-
XCKP2118P16	XCKP2145P16	XCKP2139P16	XCKP2106P16	XCPR2110P20	XCPR2102P20	XCPR2121P20	XCPR2127P20	XCPR2118P20
XCKP2518P16	XCKP2545P16	XCKP2539P16	XCKP2506P16	XCPR2510P20	XCPR2502P20	XCPR2521P20	XCPR2527P20	XCPR2518P20
XCKP2118M12	XCKP2145M12	XCKP2139M12	XCKP2106M12	-	-	-	-	-





(4) For Pg 13.5 cable entries, replace P20 by G13. Example: XCDR2110P20 becomes XCDR2110G13. For other cable entries, see customised assembly on page 7.

Heads - common to miniature and compact bodies

Metal plunger and multi-directional heads

Description	Metal end plunger	Metal end plunger with protective elastomer boot	Steel roller plunger	Retractable steel roller lever plunger	Thermoplastic roller lever plunger, horizontal actuation
					
Reference	⊕ ZCE10	⊕ ZCE11	⊕ ZCE02	⊕ ZCE24 (2)	⊕ ZCE21













Metal rotary heads and levers

Description	Rotary head without lever, spring return, for actuation from LH and RH side	Thermoplastic roller lever, track: 24/31 mm (ZCMD) 29/36 mm (ZCD/P/T)	Steel roller lever, track: 24/31 mm (ZCMD) 29/36 mm (ZCD/P/T)	Thermoplastic roller lever, track: 16/39 mm (ZCMD) 21/44 mm (ZCD/P/T)	Steel roller lever, track: 16/39 mm (ZCMD) 21/44 mm (ZCD/P/T)
					
Reference	⊕ ZCE01	⊕ ZCY15 (2)	⊕ ZCY16 (2)	⊕ ZCY25 (2)	⊕ ZCY25 (2)

(1) Recommended for use with bodies: ZCD... / ZCP... / ZCT... (2) Recommended for use with bodies: ZCMD...







Bodies

Miniature

								
Type of contact	 2-pole NO+NC Snap action	 3-pole 2NC+1NO Snap action	 2-pole NC+NO Slow break	 3-pole 2NC+1NO Slow break	 2-pole NO+NC Snap action	 2-pole NC+NO Snap action Connector 5 pin	 1-pole 1C/O Snap action Connector 4 pin	 4-pole 2NC+2NO Snap action
Reference of metal body	ZCMD21	ZCMD39	ZCMD25	ZCMD37	–	ZCMD21C12	ZCMD21M12	–
Cable								
	L = 1 m	–	–	–	–	ZCMD21L1 (3)	–	ZCMD41L1
	L = 2 m	–	–	–	–	ZCMD21L2 (3)	–	ZCMD41L2
	L = 5 m	–	–	–	–	ZCMD21L5 (3)	–	ZCMD41L5

(3) For contact 2-pole NC+NO slow break, replace 21 by 25. Example: ZCMD21L1 becomes ZCMD25L1

Connection of miniature bodies

Specific pre-cabled connection components						
	for ZCMD21	for ZCMD39	for ZCMD25	for ZCMD37		
L = 1 m	ZCMC21L1	ZCMC39L1	ZCMC25L1	ZCMC37L1		
L = 2 m	ZCMC21L2	ZCMC39L2	ZCMC25L2	ZCMC37L2		
L = 5 m	ZCMC21L5	ZCMC39L5	ZCMC25L5	ZCMC37L5	XZCP1164L2	XZCP1141L2

⊕ Positive opening operation.

(1) For PVC cable see page 47

switches

Thermoplastic roller lever plunger, vertical actuation	M12 head metal end plunger	M18 head metal end plunger	M12 head steel roller plunger	M18 head steel roller plunger	Spring rod	Spring rod with plastic end	"Cat's whisker"
⊕ ZCE27	⊕ ZCEF0(2)	⊕ ZCEH0(1)	⊕ ZCEF2(2)	⊕ ZCEH2(1)	ZCE08	ZCE07	ZCE06

Thermoplastic roller lever, track: 20/36 mm (ZCMD) 24/40 mm (ZCD/P/T)	Steel roller lever, track: 20/36 mm (ZCMD) 24/40 mm (ZCD/P/T)	Ceramic roller lever	Variable length thermoplastic roller lever	Round, glass fibre rod lever Ø 3 mm L = 125 mm	Metal spring-rod lever	Thermoplastic roller lever Ø 50 mm	Adjustable thermo-plastic roller lever Ø 50 mm
⊕ ZCY18(1)	⊕ ZCY19(1)	⊕ ZCY22	⊕ ZCY45	ZCY55	ZCY91	⊕ ZCY39	⊕ ZCY49

Compact

Type of contact											
Ref. metal body	ZCD21	ZCD39	ZCD25	ZCD27	ZCD28	ZCD29	ZCD37	ZCD21M12	-	-	-
Ref. plastic body	ZCP21	ZCP39	ZCP25	ZCP27	ZCP28	ZCP29	ZCP37	-	ZCP21M12	ZCT21P16 (2)	ZCT25P16 (2)

Connection of compact bodies

Interchangeable outlet for cable gland							Option: PUR pre-wired M12 connector, L = 2 m (1)		ZCT Pg 11 cable gland versions: replace the suffix P16 by G11. Example: ZCT21P16 becomes ZCT21G11	
Description	For ISO M16 cable gland	For ISO M20 cable gland	For Pg 11 cable gland	For Pg 13.5 cable gland	For 1/2" NPT cable gland	For PF 1/2 (G12) cable gland			ZCT 1/2" NPT versions: replace the suffix P16 by N12 (adaptor). Example: ZCT21P16 becomes ZCT21N12	
Metal	ZCDEP16	ZCDEP20	ZCDEG11	ZCDEG13	ZCDEN12	ZCDEF12	XZCP1164L2	XZCP1141L2	1 Cable entry 1/2" NPT	
Plastic	ZCPEP16	ZCPEP20	ZCPEG11	ZCPEG13	ZCPEN12	ZCPEF12			1 Cable entry Pg11	

(1) For PVC cable see page 47

ISO entry
(to EN 50262)



XCKM

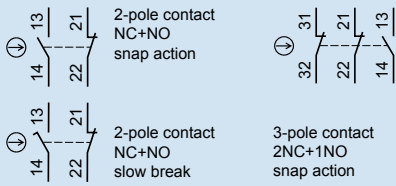

Type XCKM metal, 3 cable entries, XCKL metal, 1 cable entry

Type of operator	Metal end plunger	Steel roller plunger	Roller lever plunger, horizontal actuation in 1 direction	Thermoplastic roller lever	"Cat's whisker"
Mechanical durability (millions of operating cycles)	20	20	20	15	10
Actuation speed (in m/s)	0.5	0.5	1.5	1.5	0.5
Product certification	CE - UL - CSA - CCC - GOST - C-TICK - BV				
Degree of protection conforming to IEC 60529	IP 665				
Rated operational characteristics (conforming to EN IEC 60947-5-1)	AC-15; A300 (Ue = 240 V, Ie = 3 A) / DC-13; Q300 (Ue = 250 V, Ie = 0.27 A)				
Cable entry (1)	XCKM	3 tapped entries for ISO M20 x 1.5 cable gland (2 entries fitted with blanking plugs)			
	XCKL	1 cable entry with cable gland			
Fixing centres (mm)	41				
Body dimensions (mm) W x D x H	XCKM / XCKL	64 x 30 x 64 / 52 x 30 x 72			

Complete switch XCKM	2-pole NC+NO snap action	⊕ XCKM110H29	⊕ XCKM102H29	⊖ XCKM121H29	⊖ XCKM115H29	XCKM106H29
	2-pole NC+NO, break before make, slow break	⊕ XCKM510H29	⊕ XCKM502H29	⊖ XCKM521H29	⊖ XCKM515H29	-
Complete switch XCKL	2-pole NC+NO snap action	⊕ XCKL110	⊕ XCKL102	⊖ XCKL121	⊖ XCKL115	XCKL106

(1) For Pg 11 cable entries delete the reference suffix H29. Example: XCKM110H29 becomes XCKM110.

⊕ Positive opening operation.

Classic - XCKM, XCKL, Customised assembly - Body/contact sub-assemblies



Type XCKM metal, 3 cable entries

Type of contact

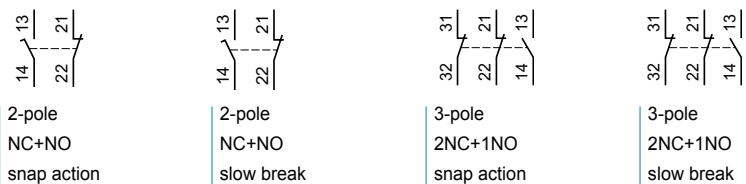

Reference of body with contact block	⊕ ZCKM1H29	⊖ ZCKM5H29	⊕ ZCKMD39H29	⊖ ZCKMD37H29
XCKL reference of body with contact block (2)	⊕ ZCKL1	⊖ ZCKL5	-	-
Reference of contact block only	⊕ XE2SP2151	⊕ XE2NP2151	⊕ XE3SP2141	⊖ XE3NP2141

(2) For cable entry 1/2" NPT, add H7. Example: XCKL1 becomes XCKL1H7

Operating heads, complete or for customer assembly



Complete switch

=



Body/contact assembly

+



Head

+



Lever

Rotary or multi-directional heads

metal head with thermoplastic roller lever

metal head with steel roller lever

with variable length thermoplastic roller lever (2)

with Ø 6 mm thermoplastic rod L = 200 mm (3)

with thermoplastic roller lever (3) for actuation from left **AND** right or left **OR** right

with "Cat's whisker"

with spring rod

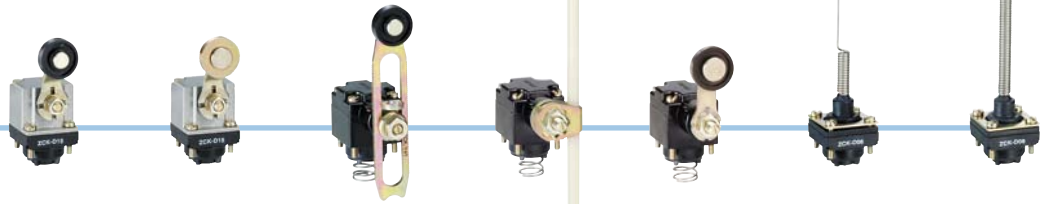

Reference

⊕ ZCKD15

⊕ ZCKD16

ZCKD41

ZCKD59

⊕ ZCKD31

ZCKD06

ZCKD08

Plunger heads

with metal end plunger

with metal end plunger and protective boot

with steel roller plunger

with steel roller plunger and protective boot

with thermoplastic roller lever plunger, horizontal actuation in 1 direction

with steel roller lever plunger, horizontal actuation in 1 direction

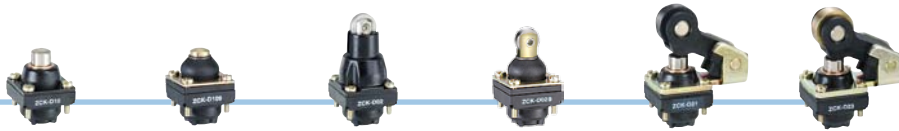

Reference

⊕ ZCKD10

⊕ ZCKD109

⊕ ZCKD02

⊕ ZCKD029

⊕ ZCKD21

⊕ ZCKD23

Rotary heads and separate levers

spring return, for actuation from left **AND** right or left **OR** right

lever with thermoplastic roller (2)

lever with steel roller (2)

variable length lever with thermoplastic roller (2)

variable length lever with steel roller (2)

rod, Ø 6 mm thermoplastic L = 200 mm (3)

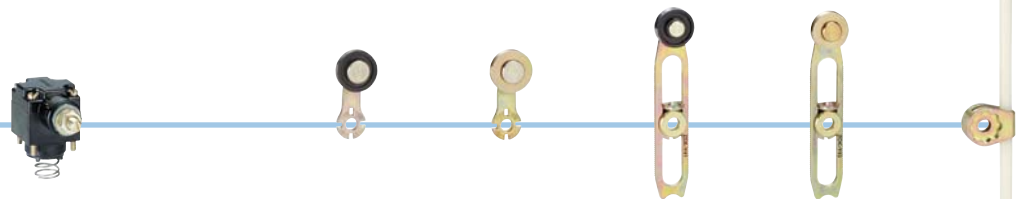

Reference

⊕ ZCKD05

⊕ ZCKY31

⊕ ZCKY33

ZCKY41

ZCKY43

ZCKY59

(2) Adjustable throughout 360° in 5° steps, or in 90° steps by reversing the notched washer.

(3) Adjustable throughout 360° in 5° steps, or in 45° steps by reversing the lever mounting.

ISO entry
(to EN 50262)



XCKJ

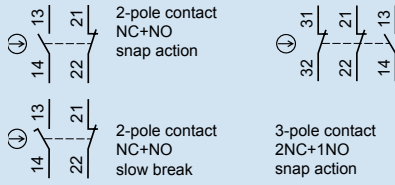

Type XCKJ metal, fixed body, conforming to standard EN 50041

Type of operator	Metal end plunger	Steel roller plunger	Thermoplastic roller lever	Steel roller lever	Variable length thermoplastic roller lever	Polyamide Ø 6 mm rod lever L = 200 mm
Mechanical durability (millions of operating cycles)	30	25	30	30	30	30
Actuation speed (in m/s)	0.5	1	1.5	1,5	1.5	1.5
Product certification	CE - UL - CSA - CCC - GOST - C-TICK - BV					
Degree of protection conforming to IEC 60529	IP 667					
Rated operational characteristics (conforming to EN IEC 60947-5-1)	AC-15; A300 (Ue = 240 V, Ie = 3 A) / DC-13; Q300 (Ue = 250 V, Ie = 0.27 A)					
Cable entry (1)	1 tapped entry for ISO M20 x 1.5 cable gland					
Fixing centres (mm)	30 x 60					
Body dimensions (mm) W x D x H	40 x 44 x 77					

Complete switch	M20	2-pole NC+NO snap action	⊕ XCKJ161H29	⊕ XCKJ167H29	⊕ XCKJ10511H29	⊕ XCKJ10513H29	XCKJ10541H29	XCKJ10559H29
		2-pole NC+NO break before make, slow break	⊕ XCKJ561H29	⊕ XCKJ567H29	⊕ XCKJ50511H29	⊕ XCKJ50513H29	XCKJ50541H29	XCKJ50559H29
	1/2" NPT	2-pole NC+NO snap action	⊕ XCKJ161H7	⊕ XCKJ167H7	⊕ XCKJ10511H7	⊕ XCKJ10513H7	XCKJ10541H7	XCKJ10559H7
		M12 5P	2-pole NC+NO snap action	⊕ XCKJ161D	⊕ XCKJ167D	⊕ XCKJ10511D	⊕ XCKJ10513D	XCKJ10541D

(1) For Pg 13.5 cable entry delete the reference suffix H29. Example: XCKJ161H29 becomes XCKJ161.

⊕ Positive opening operation.

Industrial - XCKJ, Customised assembly - Body/contact sub-assemblies

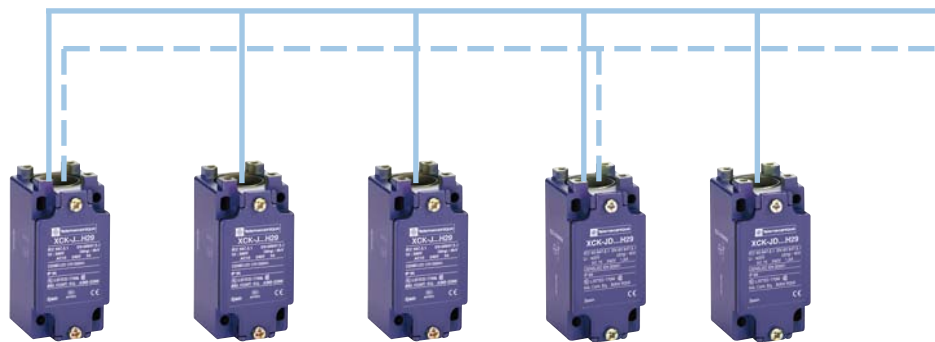

Type XCKJ metal, 1 cable entry

Type of contact

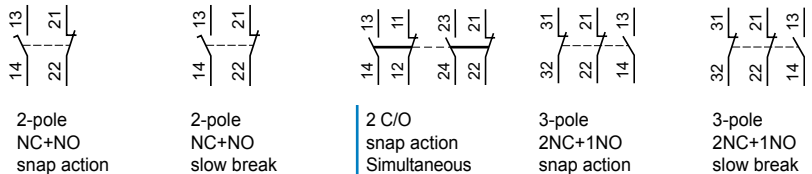

Cable entry (1)	1 tapped entry for ISO M20 x 1.5 cable gland					
Reference of body with contact block	M20	⊕ ZCKJ1H29	⊕ ZCKJ5H29	ZCKJ2H29	⊕ ZCKJD39H29	⊕ ZCKJD37H29
	Pg13	⊕ ZCKJ1	⊕ ZCKJ5	ZCKJ2	-	-
	1/2" NPT	⊕ ZCKJ1H7	⊕ ZCKJ5H7	ZCKJ2H7	-	-
	M12 (5 pin)	⊕ ZCKJ1D	⊕ ZCKJ5D	-	-	-
Reference of contact block only		⊕ XE2SP2151	⊕ XE2NP2151	-	⊕ XE3SP2141	⊕ XE3NP2141

Operating heads, complete or for customer assembly



Complete switch

=



Body/contact assembly

+



Head

+



Lever

Plunger or multi-directional heads

with reinforced steel roller end plunger

with metal end plunger

with thermoplastic roller lever plunger, 1 direct. of actuation

with steel roller lever plunger, 1 direct. of actuation

with steel roller end plunger

with steel ball bearing end plunger

End steel roller plunger with protective boot



Reference

⊖ ZCKE67

⊖ ZCKE61

⊖ ZCKE21

⊖ ZCKE23

⊖ ZCKE62

⊖ ZCKE66

⊖ ZCKE629

with metal side plunger

Side steel roller plunger, horizontal

Side steel roller plunger, vertical

with spring rod

with "Cat's whisker"

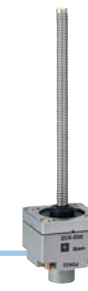

Reference

⊖ ZCKE63

⊖ ZCKE64

ZCKE65

ZCKE08

ZCKE06

Separate rotary heads and levers

spring return for actuation from left AND right or left OR right

lever with thermoplastic roller (2)

lever with steel roller (2)

variable length lever with thermoplastic roller (2)

variable length lever with steel roller (2)

rod, Ø 6 mm thermoplastic L = 200 mm (2)

square rod lever, steel, Ø 3 mm L = 125 mm (2)

round rod lever, steel, Ø 3 mm L = 125 mm (2)

spring lever with thermoplastic end (3)

spring-metal rod lever (3)

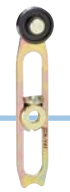

Reference

⊖ ZCKE05

⊖ ZCKY11

⊖ ZCKY13

ZCKY41

ZCKY43

ZCKY59

ZCKY51

ZCKY53

ZCKY81

ZCKY91

stay put for actuation from left AND right

forked arm lever with thermoplastic rollers, 1 track (2)

forked arm lever with thermoplastic rollers, 2 track (2)



Reference

ZCKE09

ZCKY71

ZCKY61

(2) Adjustable throughout 360° in 5° steps, or in 45° steps by reversing the lever mounting.
 (3) Adjustable throughout 360° in 5° steps, or in 90° steps by reversing the notched washer.

XCKS

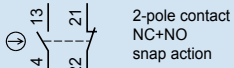

2-pole contact
NC+NO
snap action

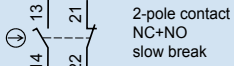

2-pole contact
NC+NO
slow break

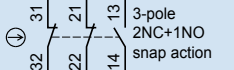

3-pole contact
2NC+1NO
snap action

XCKMR

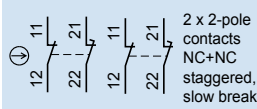

2 x 2-pole
contacts
NC+NC
staggered,
slow break

XCR

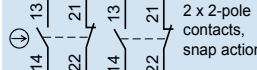

2 x 2-pole
contacts,
snap action

ISO entry
(to EN 50262)



Type XCKS plastic, double insulated, conforming to standard EN 50041

Type of operator	Metal end plunger	Steel roller plunger	Thermoplastic roller lever	Variable length thermoplastic roller lever	Rubber roller lever Ø 50 mm	Polyamide Ø 6 mm rod lever L = 200 mm
Mechanical durability (millions of operating cycles)	25	15	20	20	20	20
Actuation speed (in m/s)	0.5	0.5	1.5	1.5	1	1
Product certification	CE - UL - CSA - CCC - GOST - C-TICK					
Degree of protection conforming to IEC 60529	IP 653					
Rated operational characteristics (conforming to EN IEC 60947-5-1)	AC-15; A300 (Ue = 240 V, Ie = 3 A) / DC-13; Q300 (Ue = 250 V, Ie = 0.27 A)					
Cable entry	1 tapped entry for ISO M20 x 1.5 cable gland (1)					
Fixing centres (mm)	30 x 60					
Body dimensions (mm) W x D x H	40 x 36 x 72.5					

Complete switch 2-pole NC+NO snap action	⊕ XCKS101H29	⊕ XCKS102H29	⊕ XCKS131H29	XCKS141H29	XCKS139H29	XCKS159H29
2-pole NC+NO break before make, slow break	⊕ XCKS501H29	⊕ XCKS502H29	⊕ XCKS531H29	XCKS541H29	XCKS539H29	XCKS559H29
Body 2-pole NC+NO snap action	⊕ ZCKS1H29	⊕ ZCKS1H29	⊕ ZCKS1H29	⊕ ZCKS1H29	⊕ ZCKS1H29	⊕ ZCKS1H29
2-pole NC+NO break before make, slow break	⊕ ZCKS5H29	⊕ ZCKS5H29	⊕ ZCKS5H29	⊕ ZCKS5H29	⊕ ZCKS5H29	⊕ ZCKS5H29
3-pole 2NC+1NO snap action	⊕ ZCKSD39H29	⊕ ZCKSD39H29	⊕ ZCKSD39H29	⊕ ZCKSD39H29	⊕ ZCKSD39H29	⊕ ZCKSD39H29
Associated head (including operator)	⊕ ZCKD01	⊕ ZCKD02	⊕ ZCKD31	ZCKD41	ZCKD39	ZCKD59
Operating lever for rotary head	-	-	⊕ ZCKY31	ZCKY41	ZCKY39	ZCKY59
Complete switch Snap-action 2-pole 2X (1 NC + 1 NO) contact	-	-	-	-	-	-
Both contacts act in each direction of actuation	-	-	-	-	-	-
1 contact operates in each direction	-	-	-	-	-	-
Complete switch 2 C/O staggered snap action contacts	-	-	-	-	-	-
2 x 2 pole NC+NC staggered, slow break contacts	-	-	-	-	-	-

⊕ Positive opening operation.

(1) For Pg 13.5 cable entry delete the reference suffix H29. Example: XCKJ161H29 becomes XCKJ161.

For severe applications - XC2J, Customised assembly - Body/contact sub-assemblies



Type XC2J metal, fixed body, 1 cable entry incorporating cable gland

Type of contact



Single-pole
1 C/O contact
snap action

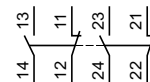

Double-pole
2 C/O simultaneous contacts
snap action

Reference of body with contact block	ZC2JC1	ZC2JC2
Reference of contact block only	XCKZ01	XESP1021

Severe duty for hoisting and materials handling applications XCKMR and XCR, complete switches



Types XCKMR and XCR "Application - hoisting, materials handling, conveying"

Square rod levers Ø 6 mm, "crossed"	Square rod levers Ø 6 mm, "crossed"	Square rod lever Ø 6 mm	Large roller rod lever Ø 50 mm	Square rod levers Ø 6 mm, "crossed" or "T"	Conveyor belt shift monitoring switches Galvanised steel operating lever	Stainless steel operating lever
2	1	10	10	10	0.3	0.3
1.5	1.5	1.5	1.5	1.5	1.5	1.5
CE - CSA - CCC - GOST						
IP 66	IP 65	IP 54			IP 66	
AC-15; A300 (Ue = 240 V, Ie = 3 A) / DC-13; Q300 (Ue = 250 V, Ie = 0.27 A)						
3 x ISO M20 x 1.5 entries	1x ISO M20x1.5 entry & 2 holes for ISO M20 cable gland	1 tapped entry for n° 13 cable gland (for ISO M20 x 1.5, adaptor DE9RA1620 must be ordered separately)				
61.5		85 x 75				105 x 70
118 x 59 x 77	116 x 66 x 77	85 x 75 x 95				85 x 87 x 146

-	-	-	-	-	-	-
-	-	-	-	-	-	-
-	-	-	-	-	-	-
-	-	-	-	-	-	-
-	-	-	-	-	-	-
-	-	-	-	-	-	-
-	-	-	-	-	-	-
-	-	-	-	-	-	-
-	-	-	-	-	-	-
-	-	☉ XCRA11(2)	☉ XCRA15	☉ XCRE18(2)	-	-
-	-	☉ XCRB11(2)	-	☉ XCRF17(3)	-	-
-	-	-	-	-	XCRT115	XCRT315 (4)
XCKMR54D1H29 (2)	XCKVR54D1H29 (2)(5)	-	-	-	-	-

(2) Steel rods, L = 200 mm

(3) Steel "T" rods, L = 200 mm, W = 300 mm.

(4) Polyester enclosure²

(5) Plastic enclosure

Operating heads, complete or for customer assembly

Plunger heads

with metal end plunger

with steel roller end plunger



Reference

ZC2JE61

ZC2JE62

Rotary heads and separate levers

spring return
for actuation from
left AND right

spring return
for actuation from
left OR right

variable length lever
with thermoplastic
roller (1)

rigid rod
3 mm, steel
L = 125 mm (1)

lever with
thermoplastic roller
(1)

lever with
steel roller (1)

spring lever
(1)

spring-rod lever



Reference

ZC2JE01

ZC2JE05

ZC2JY31

ZC2JY51

ZC2JY11

ZC2JY13

ZC2JY81

ZC2JY91

(1) Adjustable throughout 360°.

For pumping applications



Pressure range (bar) (1)	0...6	0...10	0...16	0...25	0...6	0...10	0...16	0...25	
Fluids controlled	air, fresh water								
Ambient air temperature	0...+ 80°C								
Degree of protection (IEC 60529)	IP 65								
Product certification	CE - UL - CSA								
Voltage limits	8...33 V DC for 4...20 mA, 16.2...33V DC for 0...10 V								
Dimensions (mm) Ø x L	36 x 67.5 (not including connector)								
Fluid connection (2)	G 1/4 A (male)								
Electrical connection (3)	EN 175301-803-A				M12 3 pin male				
Type of output (4)	4...20 mA, 2-wire technique, 0...10V, 3-wire technique								
Analogue output	4...20 mA	XMLK006B2C21	XMLK010B2C21	XMLK016B2C21	XMLK025B2C21	XMLK006B2D21	XMLK010B2D21	XMLK016B2D21	XMLK025B2D21
	0...10 V	XMLK006B2C71	XMLK010B2C71	XMLK016B2C71	XMLK025B2C71	XMLK006B2D71	XMLK010B2D71	XMLK016B2D71	XMLK025B2D71

(1) Also available with psi range.

(2) Also available with 1/4"-18NPT male fluid entry.

(3) Also available with 3 pin packard connector.

(4) Other types of output; 0...5 V, 0...10 V, etc.

Available in bulk packs for selling in lots. Add TQ suffix to the reference, ex: XMLK006B2C21 becomes XMLK006B2C21TQ.

Electronic sensors XMLP

Electrical connection by EN 175301-803-A connector, M12 connector

For industrial applications (hydraulic circuits, HVAC)



Pressure range (bar) (1)	0...10	0...16	0...25	0...40	0...100	0...160	0...250	0...400	
Fluids controlled	Hydraulic oils, air, fresh water, gas, refrigeration fluids from -30...+120°C								
Ambient air temperature	- 30...+ 100°C								
Degree of protection (IEC 60529)	IP 65 (EN175301-803-A), IP 65, IP 67 and IP 69K (M12 connector)								
Product certification	CE cULus								
Voltage limits	8...30 V DC for 4...20 mA, 14...30V DC for 0...10 V								
Dimensions (mm) Ø x L	30 x 26 (not including connector)								
Fluid connection (2)	G 1/4 A (male)								
Electrical connection (3)	EN 175301-803-A, M12 4 pin connector								
Type of output (4)	4...20 mA, 2-wire technique, 0...10V, 3-wire technique								
Analogue output	EN 175301-803-A	XMLP010BC21V	XMLP016BC21V	XMLP025BC21V	XMLP040BC21V	XMLP100BC22	XMLP160BC22	XMLP250BC22	XMLP400BC22
	M12 connector	XMLP010BD21V	XMLP016BD21V	XMLP025BD21V	XMLP040BD21V	XMLP100BD22	XMLP160BD22	XMLP250BD22	XMLP400BD22
Analogue output	EN 175301-803-A	XMLP010BC71V	XMLP016BC71V	XMLP025BC71V	XMLP040BC71V	XMLP100BC72	XMLP160BC72	XMLP250BC72	XMLP400BC72
	M12 connector	XMLP010BD71V	XMLP016BD71V	XMLP025BD71V	XMLP040BD71V	XMLP100BD72	XMLP160BD72	XMLP250BD72	XMLP400BD72

(1) Also available with psi range.

(2) Also available with 7/16-20UNF male or female, 1/2"-18NPT male fluid entry.

(3) Also available with 3 pin packard connector.

(4) Also available with 0.5...4.5V ratiometric output.

Available in bulk packs for selling in lots. Add Q suffix to the reference, ex: XMLP010BC21V becomes XMLP010BC21VQ.



Switch with display ZMLP

Only usable with 4-20mA analogue output pressure transmitter

Type of switching mode	Hysteresis	Windows
Displayed value range	-14,5 to 6000 with 27 selectable value ranges	
Degree of protection	IP65, IP67, and IP69K	
Product certification	CE cULus	
Power supply	24VDC (17 to 33 VDC)	
Electrical connection	Input: M12 female, 4 pin. Output: M12 male, 4 pin	
Analogue output	Switching output	
4...20 mA	PNP	ZMLPA1P2SH
4...20 mA	NPN	ZMLPA1N2SH
-	2 PNP	ZMLPA2P0SH
-	2 NPN	ZMLPA2N0SH
		ZMLPA1P2SW
		ZMLPA1N2SW
		-
		-

Accessories

Quick fixing bracket



Horizontal plan

XMLPZLH01



Vertical plan or pipe

XMLPZLV01

Electronic sensors XMLG

Electrical connection by M12 connector



Pressure range (bar) (1)	-1...0	0...1	0...6	0...10	0...16	0...25	0...100	0...250	0...400
Fluids controlled	Hydraulic oils, air, fresh water, corrosive fluids from -15...+125°C								
Ambient air temperature	- 15...+ 85°C								
Degree of protection (conforming to IEC 60529)	IP 66 and IP 67								
Product certification	CE - UL - CSA - GOST								
Voltage limits	12...24 V DC, 8...33 V DC for 4...20 mA, 11.4...33V DC for 0...10 V								
Dimensions (mm) Ø x L	Ø 22.8 x 58 (not including connector)								
Fluid connection (2)	G 1/4 A (male)								
Electrical connection (3)	M12 connector								
Type of output (4)	4...20 mA, 2-wire technique, 0...10V, 3-wire technique								
Analogue output 4...20 mA	XMLGM01D21	XMLG001D21	XMLG006D21	XMLG010D21	XMLG016D21	XMLG025D21	XMLG100D21	XMLG250D21	XMLG400D21
0...10 V	XMLGM01D71	XMLG001D71	XMLG006D71	XMLG010D71	XMLG016D71	XMLG025D71	XMLG100D71	XMLG250D71	XMLG400D71

(1) For other pressure ranges consult our web site.

(3) Also available with an integrated quick connection.

(2) Also available with 1/4"-18NPT male fluid entry.

(4) Also available with pressure switch function (digital output).

Available in bulk packs for selling in lots. Add **TQ** suffix to the reference, ex: XMLGM01D21 becomes XMLGM01D21TQ.

Electronic sensors XMLR

Electronic + Display



Adjustable pressure range (bar) (1)	-1...0	0...1	0...2,5	0...10	0...16	0...25	0...40	0...250	0...400
Fluids controlled	Hydraulic oils, air, fresh water, refrigerant fluids								
Ambient air temperature	- 20...+ 80°C								
Degree of protection (conforming to IEC 60529)	IP65, IP67 conforming to EN/IEC 60529								
Product certification	cULus conforming to UL 61010-1								
Voltage limits (V)	17...33 Vdc								
Dimensions (mm) H x W x D	93x41x42							88x41x42	
Fluid connection (2)	G1/4A (female)								
Electrical connection	M12 connector 4 pin or 5 pin								
Configurable with 4-digit display									
Analogue output 4...20 mA	XMLRM01G0T25	XMLR001G0T25	XMLR2D5G0T25	XMLR010G0T25	XMLR016G0T25	XMLR025G0T25	XMLR040G0T25	XMLR250G0T25	XMLR400G0T25
0...10 V	XMLRM01G0T75	XMLR001G0T75	XMLR2D5G0T75	XMLR010G0T75	XMLR016G0T75	XMLR025G0T75	XMLR040G0T75	XMLR250G0T75	XMLR400G0T75
Analogue + switching output 4...20 mA	XMLRM01G1P25	XMLR001G1P25	XMLR2D5G1P25	XMLR010G1P25	XMLR016G1P25	XMLR025G1P25	XMLR040G1P25	XMLR250G1P25	XMLR400G1P25
PNP - NO/NC programmable 0...10 V	XMLRM01G1P75	XMLR001G1P75	XMLR2D5G1P75	XMLR010G1P75	XMLR016G1P75	XMLR025G1P75	XMLR040G1P75	XMLR250G1P75	XMLR400G1P75
2 switching outputs PNP - NO/NC prog.	XMLRM01G2P05	XMLR001G2P05	XMLR2D5G2P05	XMLR010G2P05	XMLR016G2P05	XMLR025G2P05	XMLR040G2P05	XMLR250G2P05	XMLR400G2P05
Analogue + 2 switching outputs 4...20 mA	XMLRM01G2P25			XMLR010G2P25			XMLR040G2P25	XMLR250G2P25	XMLR400G2P25
Possible differential (bar) Min.	0.03		0,08	0,3	0,48	0,8	1,2	7,5	12
(pressure switches) Max.	0.95		2,38	9,5	15	23,8	38	238	380
Maximum permissible accidental pressure	3	7,5	12	40	62	100	150	750	1200

(1) For other pressure ranges consult our web site.

(2) Also available with 1/4"-18NPT female fluid entry.

Suitable female plug-in connectors

PUR Pre-wired connectors, L = 5 m (without LED) (5)

(5) For PVC cable see page 47

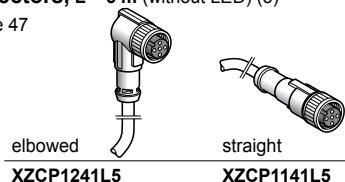

Other connectors

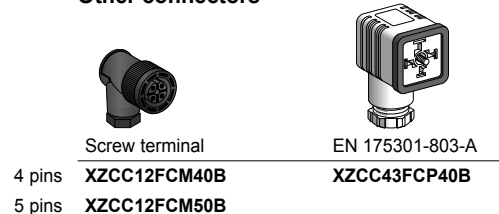



Sensors for pressure control Electromechanical pressure and vacuum switches XMLA and B

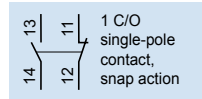

Size (bar)	-1	5	1	2.5
Environmental characteristics	Ambient air temperature (°C): - 25...+ 70 Degree of protection (conforming to IEC 60529): IP 66			
Rated operational characteristics (conforming to EN IEC 60947-5-1)	AC-15; B300 (Ue = 240 V, Ie = 1.5 A - Ue = 120 V, Ie = 3 A) / DC-13; R300 (Ue = 250 V, Ie = 0.1 A)			
Product certification	CE - UL - CSA - CCC - BV - LROS - RINA - GL - DNV - VIT-SEPRO - GOST			
Fluid connection	G 1/4" (female) (other connections possible, please consult us)			
Electrical connection	Screw terminals (1), tapped entry for ISO M20 x 1.5 cable gland - For n° 13 (DIN Pg 13.5) cable gland			

Fluids controlled	Hydraulic oils, fresh water, air up to 70°C	Hydraulic oils, air up to 160°C	Hydraulic oils, fresh water, air up to 70°C
-------------------	---	---------------------------------	---

Type XMLA - fixed differential, single threshold detection

Setting range (bar) of upper limit (PH): pressure switches	-0.28...-1 (4)	-	0.03...1	0.15...2.5
Dimensions (mm) H x W x D	113 x 35 x 75	113 x 35 x 75	162 x 110 x 110	158 x 55 x 77.5
With setting scale	1 C/O single-pole, snap action contact	-	XMLA001R2S12	XMLA002A2S12
Natural differential (bar)	at low setting	-	0.02	0.13
subtract from PH to give PB	at high setting	-	0.04	0.13

Type XMLB - adjustable differential, regulation between 2 thresholds

Setting range (bar) of upper limit (PH): pressure switches	-0.14...-1 (4)	-0.5...5	0.05...1	0.3...2.5
With setting scale	1 C/O single-pole, snap action contact	XMLBM02V2S12	XMLBM05A2S12	XMLB001R2S12
Possible differential (bar)	Min. at low setting	0.13 (3)	0.5	0.04
subtract from PH to give PB	Min. at high setting	0.13 (3)	0.5	0.06
	Max. at high setting	0.8 (3)	6	0.75
				1.75

XMLC and D

XMLC

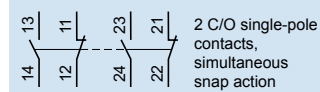

XMLD

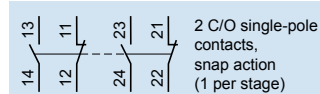

Fluids controlled	Hydraulic oils, fresh water, air up to 70°C	Hydraulic oils, air up to 160°C	Hydraulic oils, fresh water, air up to 160°C
-------------------	---	---------------------------------	--

Type XMLC - adjustable differential, regulation between 2 thresholds

Setting range (bar) of upper limit (PH): pressure switches	-0.14...-1 (4)	0.05...1	0.3...2.5
Dimensions (mm) H x W x D	113 x 46 x 85	175 x 110 x 110	158 x 55 x 90
With setting scale	2 C/O single-pole, snap action contacts	XMLCM02V2S12	XMLC001R2S12
Possible differential (bar)	Min. at low setting	0.13 (4)	0.03
subtract from PH to give PB	Min. at high setting	0.14 (4)	0.04
	Max. at high setting	0.8 (4)	0.8
			2

Type XMLD - fixed differential, dual stage, for detection at each threshold

Setting range (bar)	2 nd stage switching point (PB2)	-0.12...-1 (4)	0.12...1	0.34...2.5
	1 st stage switching point (PB1)	-0.10...-0.98	0.04...0.92	0.2...2.36
	Spread between 2 stages (PB2 - PB1)	-0.02...-0.88	0.08...0.73	0.14...1.5
Without setting scale	2 C/O single-pole, snap action contacts (1 per stage)	XMLDM02V1S12	XMLD001R1S12	XMLD002B1S12
Natural differential (bar)	at low setting	0.1 (2)	0.03	0.14
subtract from PH 1/2 to give PB 1/2	at high setting	0.1 (2)	0.07	0.19



4	10	20	35	70	160	300	500
---	----	----	----	----	-----	-----	-----

conforming to IEC 947-5-1 Appendix A, EN 60 947-5-1

tapped entry, replace the last number of the reference (2) by 1 (example: XMLA010A2S12 becomes XMLA010A2S11)

Hydraulic oils, fresh water,
air up to 70°C

Hydraulic oils up to 160°C

0.4...4	0.6...10	1...20	1.5...35	5...70	10...160	20...300	30...500
113 x 35 x 75	113 x 35 x 75	113 x 35 x 75	113 x 35 x 75	113 x 35 x 75	113 x 35 x 75	113 x 35 x 75	113 x 35 x 75
XMLA004A2S12	XMLA010A2S12	XMLA020A2S12	XMLA035A2S12	XMLA070D2S12	XMLA160D2S12	XMLA300D2S12	XMLA500D2S12
0.35	0.5	0.4	1.25	3	5.5	16.5	20
0.35	0.5	1	1.25	7.5	18	35	45

0.25...4	0.7...10	1.3...20	3.5...35	7...70	10...160	22...300	30...500
XMLB004A2S12	XMLB010A2S12	XMLB020A2S12	XMLB035A2S12	XMLB070D2S12	XMLB160D2S12	XMLB300D2S12	XMLB500D2S12
0.02	0.57	1	1.7	4.7	9.3	19.4	23
0.25	0.85	1.6	2.55	8.8	20.8	37	52.6
2.4	7.5	11	20	50	100	200	300

- (1) For electrical connection by DIN 43650A connector (IP 65), replace the suffix "S12" in the reference by "C11". Example: XMLB010A2S12 becomes XMLB010A2C11.
- (2) For vacuum switch: natural differential to be added to PB to give PH.
- (3) For vacuum switch: possible differential to be added to PB to give PH.
- (4) Setting range (bar) of lower limit (PB): vacuum switch.



Hydraulic oils, fresh water, air up to 160°C	Hydraulic oils up to 160°C
---	----------------------------

0.3...4	0.7...10	1.3...20	3.5...35	7...70	12...160	22...300	30...500
113 x 46 x 85	113 x 46 x 85	113 x 46 x 85	113 x 46 x 85	113 x 46 x 85	113 x 46 x 85	113 x 46 x 85	113 x 46 x 85
XMLC004B2S12	XMLC010B2S12	XMLC020B2S12	XMLC035B2S12	XMLC070D2S12	XMLC160D2S12	XMLC300D2S12	XMLC500D2S12
0.15	0.45	0.7	1	4.5	9	16	19
0.17	0.7	1	1.5	8.9	21	35	52
2.5	8	11	22	60	110	240	340

0.40...4	1.2...10	2.14...20	4.4...35	9.4...70	16.5...160	36...300	41...500
0.19...3.79	0.52...9.32	0.9...18.76	1.9...32.5	6.6...67.2	10.5...154	25...289	25...484
0.21...2.18	0.68...5.8	1.24...9.55	2.5...20.4	2.8...46	6...83	11...189	16...244
XMLD004B1S12	XMLD010B1S12	XMLD020B1S12	XMLD035B1S12	XMLD070D1S12	XMLD160D1S12	XMLD300D1S12	XMLD500D1S12
0.15	0.45	0.7	1.5	5	8.8	17	21
0.19	0.6	1.3	2.6	9.5	20	42	65

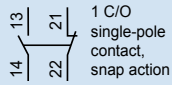

Setting range of upper limit (PH) (bar)	1...6	1.3...12	3.5...25
Fluids controlled	Air, water (fresh water, sea water) from 0...+70°C		
Ambient air temperature	- 25...+ 70°C		
Degree of protection (conforming to IEC 60529)	IP 54		
Rated operational characteristics (conforming to EN IEC 60947-5-1)	AC-15; B300 (Ue = 240 V, Ie = 1.5 A - Ue = 120 V, Ie = 3 A) / DC-13; R300 (Ue = 250 V, Ie = 0.1 A)		
Product certification	CE - UL - CSA - CCC		
Dimensions (mm) H x W x D	106 x 57 x 98		126 x 57 x 98
Fluid connection	1/4" BSP female		
Electrical connection	Screw terminals, 2 tapped entries for n° 13 (DIN Pg 13.5) cable gland		

Type XMX with internal setting screw

Without setting scale, screw terminal connections		XMXA06L2135	XMXA12L2135	XMXA25L2135
1 C/O single-pole, snap action contact				
Possible differential (bar) subtract from PH to give PB	Min. at low setting	0.8	1	3.4
	Min. at high setting	1.2	1.7	4.5
	Max. at high setting	4.2	8.4	20

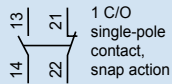

Setting range of upper limit (PH) (bar)	1...6	1.3...12	3.5...25
Fluids controlled	Air, water (fresh water, sea water) from 0...+70°C		
Ambient air temperature	- 25...+ 70°C		
Degree of protection (conforming to IEC 60529)	IP 54		
Rated operational characteristics (conforming to EN IEC 60947-5-1)	AC-15; B300 (Ue = 240 V, Ie = 1.5 A - Ue = 120 V, Ie = 3 A) / DC-13; R300 (Ue = 250 V, Ie = 0.1 A)		
Product certification	CE - UL - CSA - CCC		
Dimensions (mm) H x W x D	113 x 57 x 98		133 x 57 x 98
Fluid connection	1/4" BSP female		
Electrical connection	Screw terminals, tapped entry for n° 13 (DIN Pg 13.5) cable gland		

Type XMA with external setting screw (transparent cover)

Without setting scale, screw terminal connections		XMAV06L2135	XMAV12L2135	XMAV25L2135
1 C/O single-pole, snap action contact				
Possible differential (bar) subtract from PH to give PB	Min. at low setting	0.8	1	3.4
	Min. at high setting	1.2	1.7	4.5
	Max. at high setting	4.2	8.4	20

Electromechanical pressure switches for power circuits, adjustable differential for regulation between 2 thresholds

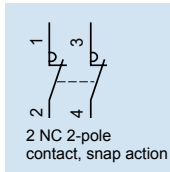

Degree of protection		IP 20			IP 65		
		4.6	7	10.5	4.6	7	10.5
Size (bar)		4.6	7	10.5	4.6	7	10.5
Setting range of upper limit (PH) (bar)		1.4...4.6	2.8...7	5.6...10.5	1.4...4.6	2.8...7	5.6...10.5
Fluids controlled		Water (fresh water, sea water) from 0...+55°C					
Electrical connection		Screw terminals, 2 cable entries with grommet			Screw terminals, 2 tapped entries for n° 13 (DIN Pg 13.5) cable gland		
Product certification		CE					
Ambient air temperature		For operation: 0...+ 50°C. For storage: - 30...+ 80°C					
Rated operational characteristics (conforming to EN IEC 60947-5-1)		Ie = 10 A, Ue = 250 V AC					
Power rating of controlled motors	110 V	AC 2-pole, single-phase	0.75 kW (1 HP)			0.75 kW (1 HP)	
		AC 2-pole, 3-phase	1.1 kW (1.5 HP)			1.1 kW (1.5 HP)	
	230 / 400 V	AC 2-pole, single-phase	1.5 kW (2 HP)			1.5 kW (2 HP)	
		AC 2-pole, 3-phase	2.2 kW (3 HP)			2.2 kW (3 HP)	
Dimensions (mm) H x W x D		96/105 x 72 x 102	94 x 72 x 102		115 x 72 x 106	115 x 72 x 106	
Fluid connection	G 1/4 (BSP female)	FSG2	FYG22	FYG32	FSG2NE	FYG22NE	FYG32NE
	R 1/4 (BSP male)	FSG9	FYG29	FYG39	-	-	-
	G 3/8 (BSP female) rotating nut	-	-	-	FSG2NEG	-	-
Possible differential subtract from PH to give PB	At low setting	1 min. - 2.1 max.	1.2 min. - 2.3 max.	1.9 min. - 3 max.	1 min. - 2.1 max.	1.2 min. - 2.3 max.	1.9 min. - 3 max.
	At middle setting	1.1 min. - 2.2 max.	1.4 min. - 2.5 max.	2.1 min. - 3.2 max.	1.1 min. - 2.2 max.	1.4 min. - 2.5 max.	2.1 min. - 3.2 max.
	At high setting	1.2 min. - 2.3 max.	1.6 min. - 2.7 max.	2.3 min. - 3.4 max.	1.2 min. - 2.3 max.	1.6 min. - 2.7 max.	2.3 min. - 3.4 max.

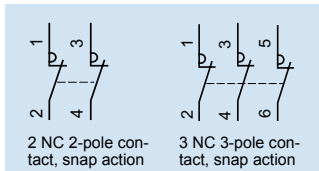

Size (bar)		6		12		25	
		1...6		1.3...12		3.5...25	
Setting range of upper limit (PH) (bar)		1...6		1.3...12		3.5...25	
Fluids controlled		Air, water (fresh water, sea water) from 0...+70°C					
Ambient air temperature		For operation: - 25...+ 70°C. For storage: - 40...+ 70°C					
Decompression valve / ONOff knob		without	with	without	with	without	
Fluid connection		G 1/4 (BSP female)	4 x G 1/4 (BSP female)	G 1/4 (BSP female)	4 x G 1/4 (BSP female)	G 1/4 (BSP female)	
Electrical connection		Screw terminals, 2 tapped entries for n° 13 (DIN Pg 13.5) cable gland					
Degree of protection		IP 54		IP 54		IP 54	
Product certification		CE - CCC					
Rated insulation voltage		Ui = 500 V					
Electrical durability	Power	1.5 kW	400 V AC 3-phase: 1 000 000 operating cycles				
		2.2 kW	400 V AC 3-phase: 600 000 operating cycles				
	3 kW	400 V AC 3-phase: 700 000 operating cycles					
		400 V AC 3-phase: 500 000 operating cycles					
Dimensions (mm) H x W x D		106 x 57 x 97.5	138 x 57 x 97.5	106 x 57 x 97.5	138 x 57 x 97.5	126 x 57 x 97.5	
Type of contacts	2 NC 2-pole, snap action contact	XMPA06B2131	-	XMPA12B2131	XMPE12B2431	XMPA25B2131	
	3 NC 3-pole, snap action contact	XMPA06C2131	XMPE06C2431	XMPA12C2131	XMPE12C2431	XMPA25C2131	
Possible differential subtract from PH to give PB	Min. at low setting	0.8	0.8	1	1	3.4	
	Min. at high setting	1.2	1.2	1.7	1.7	4.5	
	Max. at high setting	4.2	4.2	8.4	8.4	20	

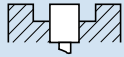

Non flush mountable



Flush mountable



	Flush standard and increased range			
	M8		M12	
Nominal sensing distance Sn	1.5 mm	2.5 mm	2 mm	4 mm
Usable sensing distance S (mm) flush mountable / non flush mountable	0...1.2	0...2	0...1.6	0...3.2
Temperature range (°C)	- 25...+ 70			
Product certification	CE - UL - CSA - CCC (in progress) - C-TICK			
Degree of protection (conforming to IEC 60529)	IP 67		pre-cabled: IP 69K conforming to DIN 40050, IP 68	

Sensors for DC applications

Output function	NO		A	A	A	A
	NC		B	B	B	B
Dimensions (mm) Ø x L Cable / Connector	M8 x 33 / M8 x 42			M12 x 35 / M12 x 50		
3-wire	PNP	Cable (2 m)	XS508B1PAL2	XS108B3PAL2	XS512B1PAL2	XS112B3PAL2
		Connector M8 / M12	XS508B1PAM8	XS108B3PAM8	XS512B1PAM12	XS112B3PAM12
	NPN	Cable (2 m)	XS508B1NAL2	XS108B3NAL2	XS512B1NAL2	XS112B3NAL2
		Connector M8 / M12	XS508B1NAM8	XS108B3NAM8	XS512B1NAM12	XS112B3NAM12
2-wire non polarised (1)	Cable (2 m)	XS508BSCAL2	XS608B3CAL2	XS512BSDAL2	XS612B3DAL2	
	Connecteur M12	XS508BSCAL01M12	XS608B3CAL01M12	XS512BSDAM12	XS612B3DAM12	
Supply voltage limits, min./max. (V) including ripple	10...36		10...36		10...36	
Switching capacity, max. (mA) 3-wire / 2-wire	200 / 100		200 / 100		200 / 100	
Overload and short-circuit protection (★) / LED output state indicator (⊗)	★ / ⊗		★ / ⊗		★ / ⊗	
Residual current, open state (mA)	≤ 0.5		≤ 0.5		≤ 0.5	
Voltage drop, closed state (V) at I nominal 3-wire / 2-wire	≤ 2 / ≤ 4		≤ 2 / ≤ 4		≤ 2 / ≤ 4	
Switching frequency (Hz) 3-wire / 2-wire	5000 / 4000		2500 / 3000		5000 / 4000	
Dimensions (mm) Ø x L Cable / connector	M8 x 51 / M8 x 62			M12 x 53 / M12 x 62		
3-wire	PNP	Cable (2 m)	XS508BLPAL2	XS608B1PAL2	XS512BLPAL2	XS612B1PAL2
		Connector M12	XS508BLPAM12	XS608B1PAM12	XS512BLPAM12	XS612B1PAM12
	NPN	Cable (2 m)	XS508BLNAL2	XS608B1NAL2	XS512BLNAL2	XS612B1NAL2
		Connector M12	XS508BLNAM12	XS608B1NAM12	XS512BLNAM12	XS612B1NAM12
2-wire non polarised	Cable (2 m)	XS508B1DAL2	XS608B1DAL2	XS512B1DAL2	XS612B1DAL2	
	Connector M12	XS508B1DAM12	XS608B1DAM12	XS512B1DAM12	XS612B1DAM12	
Supply voltage limits, min./max. (V) including ripple	10...58		10...58		10...58	
Switching capacity, max. (mA) 3-wire / 2-wire	200 / 100		200 / 100		200 / 100	
Overload and short-circuit protection (★) / LED output state indicator (⊗)	★ / ⊗		★ / ⊗		★ / ⊗	
Residual current, open state (mA) 2-wire	≤ 0.5		≤ 0.5		≤ 0.5	
Voltage drop, closed state (V) at I nominal 3-wire / 2-wire	≤ 2 / ≤ 4		≤ 2 / ≤ 4		≤ 2 / ≤ 4	
Switching frequency (Hz) 3-wire / 2-wire	5000 / 4000		2500 / 3000		5000 / 4000	

Multi-current/multi-voltage sensors for AC/DC applications

Dimensions (mm) Ø x L Cable / connector	-	-	M12 x 53 / M12 x 62	
2-wire	Cable (2 m)	-	XS512B1MAL2	XS612B1MAL2
	Connector 1/2"-20 UNF	-	XS512B1MAU20	XS612B1MAU20
Supply voltage limits, min./max. (V) including ripple	-	-	20...264	20...264
Switching capacity, max. (mA)	-	-	200	200
LED output state indicator (⊗)	-	-	⊗	⊗
Residual current, open state (mA)	-	-	≤ 0,8	≤ 0,8
Voltage drop, closed state (V) at I nominal	-	-	≤ 5.5	≤ 5.5
Switching frequency (Hz)	-	-	25 AC / 1000 DC	25 AC / 1000 DC

(1) polarised for M8 short

Accessories

Fixing for cylindrical sensors

Fixing clamp with indexing pin for cylindrical sensors

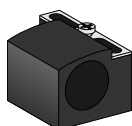

M8	XSZB108
M12	XSZB112
M18	XSZB118
M30	XSZB130

Suitable female plug-in connectors

M8	Straight	Elbowed
Metal ring	XZCC8FDM30S	XZCC8FCM30S
M12 (4 pin)		
Metal ring	XZCC12FDM40B	XZCC12FCM40B
Plastic ring	XZCC12FDP40B	XZCC12FCP40B

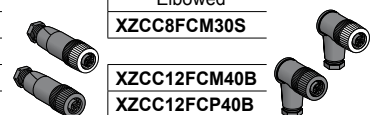



M18				M30		Non flush increased range		
5 mm		8 mm		10 mm	15 mm	M12	M18	M30
0...4		0...6.4		0...8	0...12	0...5.6	0...9.6	0...17.6
- 25...+ 70						- 25...+ 70		
CE - UL - CSA - CCC (in progress) - C-TICK						CE - UL - CSA - CCC (in progress) - C-TICK		
(with connector: IP 67)						pre-cabled: IP 69K conforming to DIN 40050, IP 68 (with connector: IP 67)		

A		A		A		A		A		A			
B		B		B		B		B		B			
M18 x 39 / M18 x 50				M30 x 43 / M30 x 55				-		-			
XS518B1PAL2		XS118B3PAL2		XS530B1PAL2		XS130B3PAL2		-		-			
XS518B1PAM12		XS118B3PAM12		XS530B1PAM12		XS130B3PAM12		-		-			
XS518B1NAL2		XS118B3NAL2		XS530B1NAL2		XS130B3NAL2		-		-			
XS518B1NAM12		XS118B3NAM12		XS530B1NAM12		XS130B3NAM12		-		-			
XS518BSDAL2		XS618B3DAL2		XS530BSDAL2		XS630B3DAL2		-		-			
XS518BSDAM12		XS618B3DAM12		XS530BSDAM12		XS630B3DAM12		-		-			
10...36		10...36		10...36		10...36		-		-			
200 / 100		200 / 100		200 / 100		200 / 100		-		-			
★ / ⊗		★ / ⊗		★ / ⊗		★ / ⊗		-		-			
≤ 0.5		≤ 0.5		≤ 0.5		≤ 0.5		-		-			
≤ 2 / ≤ 4		≤ 2 / ≤ 4		≤ 2 / ≤ 4		≤ 2 / ≤ 4		-		-			
2000 / 3000		1000 / 1000		1000 / 2000		500 / 500		-		-			
M18 x 62 / M18 x 74				M30 x 62				M12 x 55 / M12 x 65		M18 x 62 / M18 x 74		M30 x 62 / M30 x 74	
XS518BLPAL2		XS618B1PAL2		XS530BLPAL2		XS630B1PAL2		XS612B4PAL2		XS618B4PAL2		XS630B4PAL2	
XS518BLPAM12		XS618B1PAM12		XS530BLPAM12		XS630B1PAM12		XS612B4PAM12		XS618B4PAM12		XS630B4PAM12	
XS518BLNAL2		XS618B1NAL2		XS530BLNAL2		XS630B1NAL2		XS612B4NAL2		XS618B4NAL2		XS630B4NAL2	
XS518BLNAM12		XS618B1NAM12		XS530BLNAM12		XS630B1NAM12		XS612B4NAM12		XS618B4NAM12		XS630B4NAM12	
XS518B1DAL2		XS618B1DAL2		XS530B1DAL2		XS630B1DAL2		-		-		-	
XS518B1DAM12		XS618B1DAM12		XS530B1DAM12		XS630B1DAM12		-		-		-	
10...58		10...58		10...58		10...58		10...58		10...58		10...58	
200 / 100		200 / 100		200 / 100		200 / 100		200 / -		200 / -		200 / -	
★ / ⊗		★ / ⊗		★ / ⊗		★ / ⊗		★ / ⊗		★ / ⊗		★ / ⊗	
≤ 0.5		≤ 0.5		≤ 0.5		≤ 0.5		-		-		-	
≤ 2 / ≤ 4		≤ 2 / ≤ 4		≤ 2 / ≤ 4		≤ 2 / ≤ 4		≤ 2 / -		≤ 2 / -		≤ 2 / -	
2000 / 3000		1000 / 1000		1000 / 2000		500 / 500		2500 / -		1000 / -		500 / -	

M18 x 62 / M18 x 73				M30 x 62 / M30 x 73				-		M18 x 60 / M18 x 72		M30 x 63 / M30 x 74	
XS518B1MAL2		XS618B1MAL2		XS530B1MAL2		XS630B1MAL2		-		XS618B4MAL2		XS630B4MAL2	
XS518B1MAU20		XS618B1MAU20		XS530B1MAU20		XS630B1MAU20		-		XS618B4MAU20		XS630B4MAU20	
20...264		20...264		20...264		20...264		-		20...264		20...264	
300 AC / 200 DC		300 AC / 200 DC		300 AC / 200 DC		300 AC / 200 DC		-		300 AC / 200 DC		300 AC / 200 DC	
⊗		⊗		⊗		⊗		-		⊗		⊗	
≤ 0.8		≤ 0.8		≤ 0.8		≤ 0.8		-		≤ 0.8		≤ 0.8	
≤ 5.5		≤ 5.5		≤ 5.5		≤ 5.5		-		≤ 5.5		≤ 5.5	
25 AC / 1000 DC		25 AC / 1000 DC		25 AC / 500 DC		25 AC / 500 DC		-		25 AC / 1000 DC		25 AC / 300 DC	

PUR pre-wired connectors (1)

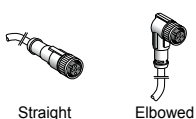

Straight Elbowed

M8 (3 pin)		1/2"		M12 (4 pin)		
	Straight	Elbowed		Straight	Elbowed	Elbowed PNP LED
2 m	XZCP0566L2	XZCP0666L2	2 m	XZCP1865L2	XZCP1965L2	2 m XZCP1141L2 XZCP1241L2 XZCP1340L2
5 m	XZCP0566L5	XZCP0666L5	5 m	XZCP1865L5	XZCP1965L5	5 m XZCP1141L5 XZCP1241L5 XZCP1340L5
10 m	XZCP0566L10	XZCP0666L10	10 m	XZCP1865L10	XZCP1965L10	10 m XZCP1141L10 XZCP1241L10 XZCP1340L10

(1) For PVC cable see page 47

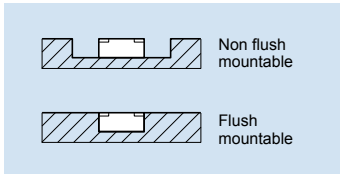

	∅ 8 x 22 x 8	∅ 15 x 32 x 8	∅ 26 x 26 x 13	∅ 40 x 40 x 15	∅ 80 x 80 x 26
Nominal sensing distance S_n	2.5 mm	5 mm	10 mm	15 mm	40 mm
Usable sensing distance S (mm) flush mountable / non flush mountable	0...2	0...4	0...8	0...12	0...32
Fine adjustment zone (mm) flush mountable / non flush mountable	–	–	–	–	–
Suitability for flush mounting (metal environment)	flush mountable	flush mountable	flush mountable	flush mountable	flush mountable
Temperature range (°C)	- 25...+ 70	- 25...+ 70	- 25...+ 70	- 25...+ 70	- 25...+ 70
Product certification	CE	CE - UL - CSA - C-TICK			
Degree of protection (conforming to IEC 60529)	pre-cabled: IP 68 (with connector: IP 67)				

Sensors for DC applications

Connection			Pre-cabled, PvR (2 m)				
2-wire (non polarised)	NO or NC	programmable	–	–	–	–	–
2-wire non polarised	NO function		XS7J1A1DAL2	XS7F1A1DAL2	XS7E1A1DAL2	XS7C1A1DAL2	XS7D1A1DAL2
	NC function		XS7J1A1DBL2	XS7F1A1DBL2	XS7E1A1DBL2	XS7C1A1DBL2	XS7D1A1DBL2
4-wire	PNP	NO + NC complementary outputs	–	–	–	–	–
	NPN	NO + NC complementary outputs	–	–	–	–	–
3-wire	PNP	NO function	XS7J1A1PAL2	XS7F1A1PAL2	XS7E1A1PAL2	XS7C1A1PAL2	XS7D1A1PAL2
		NC function	XS7J1A1PBL2	XS7F1A1PBL2	XS7E1A1PBL2	XS7C1A1PBL2	XS7D1A1PBL2
	NPN	NO function	XS7J1A1NAL2	XS7F1A1NAL2	XS7E1A1NAL2	XS7C1A1NAL2	XS7D1A1NAL2
		NC function	XS7J1A1NBL2	XS7F1A1NBL2	XS7E1A1NBL2	XS7C1A1NBL2	XS7D1A1NBL2
Connection			M8 connector		M12 connector		
2-wire non polarised	NO function		XS7J1A1DAL01M8 (1)	XS7F1A1DAL01M8 (1)	XS7E1A1DAM8	XS7C1A1DAM8	XS7D1A1DAM12
	NC function		XS7J1A1DBL01M8 (1)	XS7F1A1DBL01M8 (1)	XS7E1A1DBM8	XS7C1A1DBM8	XS7D1A1DBM12
3-wire	PNP	NO function	XS7J1A1PAL01M8 (1)	XS7F1A1PAL01M8 (1)	XS7E1A1PAM8	XS7C1A1PAM8	XS7D1A1PAM12
		NC function	XS7J1A1PBL01M8 (1)	XS7F1A1PBL01M8 (1)	XS7E1A1PBM8	XS7C1A1PBM8	XS7D1A1PBM12
	NPN	NO function	XS7J1A1NAL01M8 (1)	XS7F1A1NAL01M8 (1)	XS7E1A1NAM8	XS7C1A1NAM8	XS7D1A1NAM12
		NC function	XS7J1A1NBL01M8 (1)	XS7F1A1NBL01M8 (1)	XS7E1A1NBM8	XS7C1A1NBM8	XS7D1A1NBM12
Supply voltage limits, min./max. (V) including ripple			10...36	10...36	10...36	10...36	10...36
Switching capacity, max. (mA)			100	100	100	100	100
Short-circuit protect. (★) / LED output state indicator (⊗) / Power on LED (⊗)			★ / ⊗ / –	★ / ⊗ / –	★ / ⊗ / –	★ / ⊗ / –	★ / ⊗ / –
Voltage drop, closed state (V) at I nominal cable / Connector			≤ 4 / ≤ 2	≤ 4 / ≤ 2	≤ 2	≤ 2	≤ 2
Switching frequency (Hz) cable / Connector			4000 / 2000	5000 / 2000	1000	1000	100

Multi-current/multi-voltage sensors for AC/DC applications

Connection							
2-wire	AC/DC	NO function	–	–	–	–	–
		NC function	–	–	–	–	–
	AC	NO or NC programmable	–	–	–	–	–
		NO or NC programmable	–	–	–	–	–
Connection							
2-wire	AC/DC	NO function	–	–	–	–	–
		NC function	–	–	–	–	–
Supply voltage limits, min./max. (V) including ripple			–	–	–	–	–
Switching capacity, max. (mA)			–	–	–	–	–
Short-circuit protect. (★) / LED output state indicator (⊗) / Power on LED (⊗)			–	–	–	–	–
Residual current, open state (mA)			–	–	–	–	–
Voltage drop, closed state (V) at I nominal			–	–	–	–	–
Switching frequency (Hz)			–	–	–	–	–

(1) M8 connector on flying lead (L = 0.15 m).

Accessories

Fixing for flat sensors

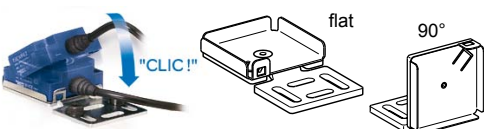

	flat	90°
8x22x8	XSZBJ00	XSZBJ90
15x32x8	XSZBF00	XSZBF90
26x26x13	XSZBE00	XSZBE90
40x40x15	XSZBC00	XSZBC90

Suitable female plug-in connectors

	M8	Straight	Elbowed
	Metal ring	XZCC8FDM30S	XZCC8FCM30S
	M12 (4 pin)		
	Metal ring	XZCC12FDM40B	XZCC12FCM40B
	Plastic ring	XZCC12FDP40B	XZCC12FCP40B



Ø 40 x 40 x 70		Ø 40 x 40 x 117		Ø 26 x 26 x 13	Ø 40 x 40 x 15	Ø 80 x 80 x 26
20 mm	40 mm	20 mm	40 mm	15 mm	25 mm	60 mm
0...16	0...32	0...16	0...32	0...8 / 0...12	0...12 / 0...20	0...32 / 0...48
flush mountable	non flush mountable	flush mountable	non flush mountable	5...10 / 5...15	8...15 / 8...25	20...40 / 20...60
- 25...+ 70				flush mountable or non flush mountable via teach mode		
CE - UL - CSA - CCC - C-TICK				CE - UL - CSA - CCC - C-TICK		
IP67 and IP69K				pre-cabled: IP 68 (with connector: IP 67)		

M12 connector		Screw terminals (2)		Pre-cabled (2 m)		
-	-	XS8C4A1DPP20	XS8C4A4DPP20	-	-	-
XS8C2A1DAM12	XS8C2A4DAM12	-	-	-	-	-
XS8C2A1DBM12	XS8C2A4DBM12	-	-	-	-	v
XS8C2A1PCM12	XS8C2A4PCM12	XS8C4A1PCP20	XS8C4A4PCP20	-	-	-
XS8C2A1NCM12	XS8C2A4NCM12	XS8C4A1NCP20	XS8C4A4NCP20	-	-	-
-	-	-	-	XS8E1A1PAL2	XS8C1A1PAL2	XS8D1A1PAL2
-	-	-	-	XS8E1A1PBL2	XS8C1A1PBL2	XS8D1A1PBL2
-	-	-	-	XS8E1A1NAL2	XS8C1A1NAL2	XS8D1A1NAL2
-	-	-	-	XS8E1A1NBL2	XS8C1A1NBL2	XS8D1A1NBL2
				M8 connector		M12 connector
-	-	-	-	-	-	-
-	-	-	-	-	-	-
-	-	-	-	XS8E1A1PAM8	XS8C1A1PAM8	XS8D1A1PAM12
-	-	-	-	XS8E1A1PBM8	XS8C1A1PBM8	XS8D1A1PBM12
-	-	-	-	XS8E1A1NAM8	XS8C1A1NAM8	XS8D1A1NAM12
-	-	-	-	XS8E1A1NBM8	XS8C1A1NBM8	XS8D1A1NBM12
12...48				10...36	10...36	10...36
4-wire version = 200	2-wire version = 1.5...100			100	200	200
4-wire version = ★ / ⊗ / ⊗	2-wire version = ★ / ⊗ / -			★ / ⊗ / ⊗	★ / ⊗ / ⊗	★ / ⊗ / ⊗
4-wire version = ≤ 2	2-wire version = ≤ 4			≤ 2	≤ 2	≤ 2
flush version : 300	Non flush version : 200			2000	1000	150

1/2" - 20 UNF connector		Screw terminals (2)		Pre-cabled (2 m)		
XS8C2A1MAU20	XS8C2A4MAU20	-	-	XS8E1A1MAL2	XS8C1A1MAL2	XS8D1A1MAL2
XS8C2A1MBU20	XS8C2A4MBU20	-	-	XS8E1A1MBL2	XS8C1A1MBL2	XS8D1A1MBL2
-	-	-	-	-	-	-
-	-	XS8C4A1MPP20	XS8C4A4MPP20	-	-	-
				1/2"-20 UNF connector		
-	-	-	-	XS8E1A1MAL01U20	XS8C1A1MAL01U20	XS8D1A1MAU20
-	-	-	-	XS8E1A1MBL01U20	XS8C1A1MBL01U20	XS8D1A1MBU20
20...264				20...264	20...264	20...264
AC/DC version = 300 / 200				200 AC or DC	300 AC / 200 DC	300 AC / 200 DC
- / ⊗ / -				- / ⊗ / ⊗	- / ⊗ / ⊗	- / ⊗ / ⊗
AC/DC version = ≤ 1.5				≤ 1.5	≤ 1.5	≤ 1.5
≤ 5.5				≤ 5.5	≤ 5.5	≤ 5.5
25 AC / 50 DC				2000	1000	150

(2) Sensors supplied without cable gland. Suitable cable gland: M20. Also available in 13P, 1/2" NPT output and M12, 7/8" connectors.

PUR pre-wired connectors (1)		M8 (3 pin)		1/2"		M12 (4 pin)					
		Straight	Elbowed		Straight	Elbowed	Straight	Elbowed	Elbowed PNP LED		
		2 m	XZCP0566L2	XZCP0666L2	2 m	XZCP1865L2	XZCP1965L2	2 m	XZCP1141L2	XZCP1241L2	XZCP1340L2
		5 m	XZCP0566L5	XZCP0666L5	5 m	XZCP1865L5	XZCP1965L5	5 m	XZCP1141L5	XZCP1241L5	XZCP1340L5
		10 m	XZCP0566L10	XZCP0666L10	10 m	XZCP1865L10	XZCP1965L10	10 m	XZCP1141L10	XZCP1241L10	XZCP1340L10

(1) For PVC cable see page 47

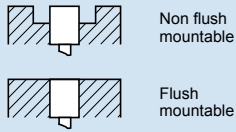

	M8	M12	M18	M30
Nominal sensing distance S_n	2.5 mm	4 mm	8 mm	15 mm
Operating zone (mm)	0...2	0...3.2	0...6.4	0...12
Suitability for flush mounting (metal environment)	non flush mountable			
Temperature range (°C)	- 25...+ 70			
Product certification	CE - UL - CSA - CCC - C-TICK			
Degree of protection (conforming to IEC 60529)	IP 67	pre-cabled: IP 68 (with connector: IP 67)		

Sensors for DC applications

Connection			Pre-cabled, PvR (2 m)			
Dimensions (mm) Ø x L			M8 x 33	M12 x 33	M18 x 33.5	M30 x 40.5
3-wire	PNP	NO function	XS4P08PA340	XS4P12PA340	XS4P18PA340	XS4P30PA340
		NC function	XS4P08PB340	XS4P12PB340	XS4P18PB340	XS4P30PB340
	NPN	NO function	XS4P08NA340	XS4P12NA340	XS4P18NA340	XS4P30NA340
		NC function	XS4P08NB340	XS4P12NB340	XS4P18NB340	XS4P30NB340
Connection			M8 connector	M12 connector		
Dimensions (mm) Ø x L			M8 x 42	M12 x 48	M18 x 48	M30 x 50
3-wire	PNP	NO function	XS4P08PA340S	XS4P12PA340D	XS4P18PA340D	XS4P30PA340D
		NC function	XS4P08PB340S	XS4P12PB340D	XS4P18PB340D	XS4P30PB340D
	NPN	NO function	XS4P08NA340S	XS4P12NA340D	XS4P18NA340D	XS4P30NA340D
		NC function	XS4P08NB340S	XS4P12NB340D	XS4P18NB340D	-
Supply voltage limits, min./max. (V) including ripple			10...38	10...38	10...38	10...38
Switching capacity, max. (mA)			200	200	200	200
Short-circuit protect. (★) / LED output state indicator (⊗)			★ / ⊗	★ / ⊗	★ / ⊗	★ / ⊗
Voltage drop, closed state (V) at I nominal			≤ 2	≤ 2	≤ 2	≤ 2
Switching frequency (Hz)			5000	5000	2000	1000

Multi-current/multi-voltage sensors for AC/DC applications

Connection			Pre-cabled, PvR (2 m)			
Dimensions (mm) Ø x L			M8 x 50	M12 x 50	M18 x 60	M30 x 60
2-wire	AC/DC	NO function	XS4P08MA230	XS4P12MA230	XS4P18MA230	XS4P30MA230
		not short-circuit protected (1) NC function	XS4P08MB230	XS4P12MB230	XS4P18MB230	XS4P30MB230
Connection			1/2" connector			
Dimensions (mm) Ø x L			M8 x 61	M12 x 61	M18 x 70	M30 x 70
2-wire	AC/DC	NO function	XS4P08MA230K	XS4P12MA230K	XS4P18MA230K	XS4P30MA230K
		not short-circuit protected (1) NC function	XS4P08MB230K	XS4P12MB230K	XS4P18MB230K	XS4P30MB230K
Supply voltage limits, min./max. (V) including ripple			20...264	20...264	20...264	20...264
Switching capacity, max. (mA)			100	200	300 AC / 200 DC	300 AC / 200 DC
LED output state indicator (⊗)			⊗	⊗	⊗	⊗
Residual current, open state (mA)			≤ 0.6	≤ 0.6	≤ 0.6	≤ 0.6
Voltage drop, closed state (V) at I nominal			≤ 5.5	≤ 5.5	≤ 5.5	≤ 5.5
Switching frequency (Hz)			25 AC / 3000 DC	25 AC / 3000 DC	25 AC / 2000 DC	25 AC / 1000 DC

(1) For these sensors without short-circuit protection, it is essential to connect a 0.4 A quick-blow fuse in series with the load.

Accessories

Fixing for cylindrical sensors

Fixing clamp with indexing pin for cylindrical sensors

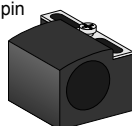

M4	XSZB104	M12	XSZB112
M5	XSZB105	M18	XSZB118
M6.5	XSZB165	M30	XSZB130
M8	XSZB108		

Suitable female plug-in connectors

	Straight	Elbowed
M8		
Metal ring	XZCC8FDM30S	XZCC8FCM30S
M12 (4 pin)		
Metal ring	XZCC12FDM40B	XZCC12FCM40B
Plastic ring	XZCC12FDP40B	XZCC12FCP40B

Miniature cylindrical metal (assembly)



	Ø 4	M5	Ø 6.5	
Nominal sensing distance Sn	1 mm	1 mm	1.5 mm	2.5 mm
Operating zone (mm)	0...0.8	0...0.8	0...1.2	0...2
Suitability for flush mounting (metal environment)	flush mountable			
Temperature range (°C)	- 25...+ 70			
Product certification	CE - UL - CSA - CCC - C-TICK			
Degree of protection (conforming to IEC 60529)	IP 67			

Sensors for DC applications

Dimensions (mm) Ø x L		Ø 4 x 29	M5 x 29	Ø 6.5 x 33		
Connection		Pre-cabled, PvR (2 m)				
3-wire	PNP	NO function	XS1L04PA310	XS1N05PA310	XS506B1PAL2	XS106B3PAL2
		NC function	–	–	XS506B1PBL2	XS106B3PBL2
	NPN	NO function	XS1L04NA310	XS1N05NA310	XS506B1NAL2	XS106B3NAL2
		NC function	–	–	XS506B1NBL2	XS106B3NBL2
2-wire (polarised)	NO function	–	–	XS506BSCAL2	XS606B3CAL2	
	NC function	–	–	XS506BSCBL2	XS606B3CBL2	
Dimensions (mm) Ø x L		Ø 4 x 41	M5 x 41	Ø 6.5 x 42		
Connection		M8				
3-wire	PNP	NO function	XS1L04PA310S	XS1N05PA311S (1)	XS506B1PAM8	XS106B3PAM8
		NC function	–	–	XS506B1PBM8	XS106B3PBM8
	NPN	NO function	XS1L04NA310S	XS1N05NA311S (1)	XS506B1NAM8	XS106B3NAM8
		NC function	–	–	XS506B1NBM8	XS106B3NBM8
Connection		M12				
2-wire (polarised)	fonction NO	–	–	XS506BSCAL01M12	XS506B3CAL01M12	
Supply voltage limits, min./max. (V) including ripple		5...30	5...30	10...36		
Switching capacity, max. (mA) 3-wire / 2-wire		100 / –	100 / –	200 / 100		
Short-circuit protect. (★) / LED output state indicator (⊗)		★ / ⊗	★ / ⊗	★ / ⊗		
Voltage drop, closed state (V) at I nominal 3-wire / 2-wire		≤ 2 / –	≤ 2 / –	≤ 2 / ≤ 4		
Switching frequency (Hz) 3-wire / 2-wire		5000 / –	5000 / –	5000 / 4000	2500 / 3000	

(1) Stainless steel sensors, Sn = 0.8 mm

PUR pre-wired connectors (1)

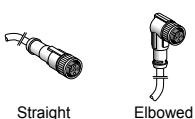

Straight Elbowed

	M8 (3 pin)		1/2"		M12 (4 pin)				
	Straight	Elbowed	Straight	Elbowed	Straight	Elbowed	Elbowed PNP LED		
2 m	XZCP0566L2	XZCP0666L2	2 m	XZCP1865L2	XZCP1965L2	2 m	XZCP1141L2	XZCP1241L2	XZCP1340L2
5 m	XZCP0566L5	XZCP0666L5	5 m	XZCP1865L5	XZCP1965L5	5 m	XZCP1141L5	XZCP1241L5	XZCP1340L5
10 m	XZCP0566L10	XZCP0666L10	10 m	XZCP1865L10	XZCP1965L10	10 m	XZCP1141L10	XZCP1241L10	XZCP1340L10

(1) For PVC cable see page 47

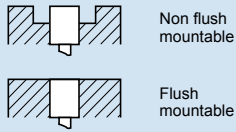

		M12	M18	M30
Sensing distance Sn	flush mountable	2 mm	5 mm	10 mm
	non flush mountable	4 mm	8 mm	15 mm
Operating zone (mm)	flush mountable	0...1.6	0...4	0...8
	non flush mountable	0...3.2	0...6.4	0...12
Suitability for flush mounting (metal environment)		flush mountable or non flush mountable depending on model		
Case M (metal) P (plastic)		M		
Temperature range (°C)		- 25...+ 70		
Degree of protection (conforming to IEC 60529)		IP 68 (with connector: IP 67)		
Product certification		CE - UL - CSA - CCC - C-TICK		
Dimensions (mm) Ø x L Cable (Connector)		M12 x 55 (M12 x 66)	M18 x 60 (M18 x 72)	M30 x 60 (M30 x 72)

Sensors for DC applications

Connection						
4-wire	PNP	NO + NC	flush mountable	-	-	-
			non flush mountable	-	-	-
	NPN	NO + NC	flush mountable	-	-	-
			non flush mountable	-	-	-
	PNP+NPN programmable	NO/NC	flush mountable (metal)	-	-	-
			non flush mntbl. (metal)	-	-	-
		non flush mntbl. (plastic)	-	-	-	
Connection						
4-wire	PNP	NO + NC	flush mountable	-	-	-
			non flush mountable	-	-	-
	NPN	NO + NC	flush mountable	-	-	-
			non flush mountable	-	-	-
	PNP+NPN programmable	NO/NC	flush mountable (metal)	-	-	-
			non flush mntbl. (metal)	-	-	-
		non flush mntbl. (plastic)	-	-	-	
Supply voltage limits, min./max. (V) including ripple				-	-	-
Switching capacity, max. (mA)				-	-	-
Short-circuit protection (★) / LED output state indicator (⊗)				-	-	-
Voltage drop, closed state (V) at I nominal				-	-	-
Switching frequency (Hz)				-	-	-

Multi-current/multi-voltage sensors for AC/DC applications

Connection			Pre-cabled, PvR (2 m)		
2-wire AC/DC	NO function	flush mountable	XS1M12MA250	XS1M18MA250	XS1M30MA250
		non flush mountable	XS2M12MA250	XS2M18MA250	XS2M30MA250
	NC function	flush mountable	XS1M12MB250	XS1M18MB250	XS1M30MB250
		non flush mountable	XS2M12MB250	XS2M18MB250	XS2M30MB250
Connection			1/2"-20 UNF connector		
2-wire AC/DC	NO function	flush mountable	XS1M12MA250K	XS1M18MA250K	XS1M30MA250K
		non flush mountable	XS2M12MA250K	XS2M18MA250K	XS2M30MA250K
	NC function	flush mountable	XS1M12MB250K	XS1M18MB250K	XS1M30MB250K
		non flush mountable	-	XS2M18MB250K	XS2M30MB250K
Supply voltage limits, min./max. (V) 50-60 Hz			20...264		
Switching capacity, max. (mA)			5...200		
LED output state indicator (⊗) / Power on LED (⊗)			⊗ / ⊗		
Residual current, open state (mA)			≤ 1.5		
Voltage drop, closed state (V) at I nominal			≤ 5.5		
Switching frequency (Hz)			25 AC, 4000 DC	25 AC, 2000 DC	25 AC, 2000 DC (1)

(1) 25 AC, 1000 DC for non flush mountable Ø 30 mm.

PNP or NPN NO + NC Complementary outputs

PNP + NPN outputs, NO or NC programmable



M8	M12	M18	M30	M12	M18	M30
1.5 mm	2 mm	5 mm	10 mm	2 mm	5 mm	10 mm
2.5 mm	4 mm	8 mm	15 mm	4 mm	8 mm	15 mm
0...1.2	0...1.6	0...4	0...8	0...1.6	0...4	0...8
0...2	0...3.2	0...6.4	0...12	0...3.2	0...6.4	0...12
flush mountable or non flush mountable depending on model				flush mountable or non flush mountable depending on model		
M				M or P depending on model		
- 25...+ 70				- 25...+ 70		
IP 67		IP 68 (with connector: IP 67)				
CE - UL - CSA - CCC - C-TICK						
M8 x 50 (M8 x 61)	M12 x 33 (M12 x 48)	M18 x 36.5 (M18 x 49)	M30 x 40.5 (M30 x 53)	M12 x 50 (M12 x 61)	M18 x 60 (M18 x 72)	M30 x 60 (M30 x 72)

Pre-cabled, PvR (2 m)				Pre-cabled, PvR (2 m)		
XS1M08PC410	XS1N12PC410	XS1N18PC410	XS1N30PC410	-	-	-
XS2M08PC410	XS2N12PC410	XS2N18PC410	XS2N30PC410	-	-	-
XS1M08NC410	XS1N12NC410	XS1N18NC410	XS1N30NC410	-	-	-
XS2M08NC410	XS2N12NC410	XS2N18NC410	XS2N30NC410	-	-	-
-	-	-	-	XS1M12KP340	XS1M18KP340	XS1M30KP340
-	-	-	-	XS2M12KP340	XS2M18KP340	XS2M30KP340
-	-	-	-	XS4P12KP340	XS4P18KP340	XS4P30KP340
M12 connector				M12 connector		
XS1M08PC410D	XS1N12PC410D	XS1N18PC410D	XS1N30PC410D	-	-	-
XS2M08PC410D	XS2N12PC410D	XS2N18PC410D	XS2N30PC410D	-	-	-
XS1M08NC410D	XS1N12NC410D	XS1N18NC410D	XS1N30NC410D	-	-	-
XS2M08NC410D	XS2N12NC410D	XS2N18NC410D	XS2N30NC410D	-	-	-
-	-	-	-	XS1M12KP340D	XS1M18KP340D	XS1M30KP340D
-	-	-	-	XS2M12KP340D	XS2M18KP340D	XS2M30KP340D
-	-	-	-	XS4P12KP340D	XS4P18KP340D	XS4P30KP340D
10...36				10...36		
200				200		
★ / ⊗				★ / -		
≤ 2				≤ 2.6		
5000	5000	2000	1000	5000	2000	1000

PNP

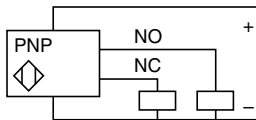

NPN

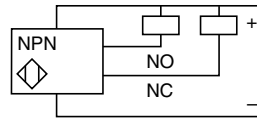

NO

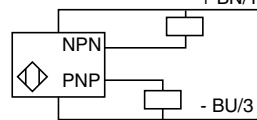

NC

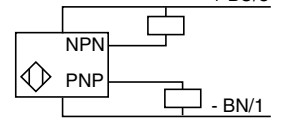

Accessories

Fixing clamps

With indexing pin for cylindrical sensors



M8	XSZB108
M12	XSZB112
M18	XSZB118
M30	XSZB130

Suitable female plug-in connectors, including PUR pre-wired versions (1)

length 5 m
without LED

M8 (or S)
M12 (or D)
1/2" (or K)

pre-wired,
elbowed

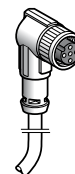

pre-wired,
straight

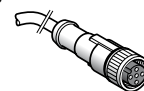

XZCP0566L5
XZCP1141L5
XZCP1865L5

screw terminal



XZCC8FCM30S
XZCC12FCM40B
XZCC20FCM30B

(1) For PVC cable see page 47

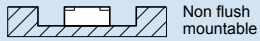

Non flush mountable

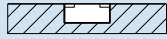

Flush mountable



	26 x 26 x 13	40 x 40 x 15	M30	M18	M30
Nominal sensing distance S_n	10 mm	15 mm	10 mm	5 mm	10 mm
Operating zone (mm)	0...8	0...12	0...8	0...4	0...8
Suitability for flush mounting (metal environment)	flush mountable			flush mountable	
Case M (metal) P (plastic)	P	P	M	M	M
Temperature range (°C)	- 25...+ 70			0...+ 50	
Degree of protection (conforming to IEC 60529)	IP 67			pre-cabled: IP 68 (with connector: IP 67)	
Product certification	CE - UL - CSA - CCC - C-TICK			CE - UL - CSA - CCC - C-TICK	
Dimensions (mm) Ø x L or W x H x D Cable (Connector)	26 x 26 x 13	40 x 40 x 15	M30 x 81	M18 x 60 (M18 x 70)	M30 x 60
Maximum speed of passing object (impulses/min)	48000	48000	6000...48000 (1)	-	-
Adjustable frequency range (impulses/min)	6...6000	6...6000	6...150 / 120...3000 (1)	-	-

Sensors for DC applications

Connection			Pre-cabled, PvR (2 m)				
4-wire	PNP/NPN NO/NC	programmable	-	-	-	XS1M18KPM40	XS1M30KPM40
3-wire	PNP NC function	slow version	-	-	XSAV11373	-	-
		fast version	-	-	XSAV12373	-	-
	0...10 V output	plastic	-	-	-	-	-
	4...20 mA output	metal, flush mountable	-	-	-	-	-
		plastic, flush mountable	-	-	-	-	-
		plastic, non flush mountable	-	-	-	-	-
Connection			M8 or M12 connector				
4-wire	PNP/NPN NO/NC	programmable	-	-	-	XS1M18KPM40D	XS1M30KPM40LD
3-wire	PNP NC function		XS9E11RPBL01M12 (3)	XS9C11RPBL01M12 (3)	-	-	-
		0...10 V output	-	-	-	-	-
	4...20 mA output		-	-	-	-	-
Supply voltage limits, min./max. (V) including ripple			10...36	10...36	10...58	10...38	
Switching capacity, max. (mA)			100	200	200	200	
Short-circuit protect. (★) / LED output state indicator (⊗) / Power on LED (⊗)			(⊗)	★ / ⊗ / ⊗	★ / ⊗ / ⊗	★ / ⊗ / -	★ / ⊗ / -
Linearity error			-	-	-	-	-
Voltage drop, closed state (V) at I nominal			≤ 2	≤ 2	≤ 2	≤ 2.6	
Switching frequency (Hz)			-	-	-	1000	
Operating frequency (Hz)			-	-	-	-	

Multi-current/multi-voltage sensors for AC/DC applications

Connection			Pre-cabled, PvR (2 m)				
2-wire	AC/DC	NC function	XS9E11RMBL01U20 (5)	XS9C11RMBL01U20 (5)	-	-	-
not short-circuit protected (2)	NC function	slow version	-	-	XSAV11801	-	-
		fast version	-	-	XSAV12801	-	-
Supply voltage limits, min./max. (V) 50-60 Hz			20...264	20...264	20...264	-	-
Switching capacity, max. (mA)			100	300 AC / 200 DC	300 AC / 200 DC	-	-
LED output state indicator (⊗) / Power on LED (⊗)			⊗ / ⊗	⊗ / ⊗	⊗ / -	-	-
Residual current, open state (mA)			≤ 1.5	≤ 1.5	≤ 1.5	-	-
Voltage drop, closed state (V) at I nominal			≤ 5.5	≤ 5.5	≤ 5.7	-	-
Switching frequency (Hz)			-	-	-	-	-

Accessories

Fixing

for flat sensors

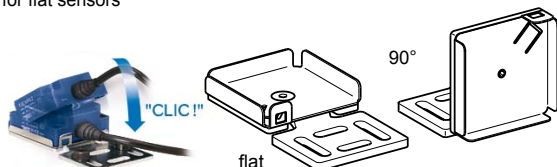

	flat	90°	substitution of block type sensors XSE / XSC / XSD
8x22x8	XSZBJ00	XSZBJ90	-
15x32x8	XSZBF00	XSZBF90	XSZBE10
26x26x13	XSZBE00	XSZBE90	XSZBC10
40x40x15	XSZBC00	XSZBC90	XSZBD10

Fixing clamp with indexing pin for cylindrical sensors



M12	XSZB112
M18	XSZB118
M30	XSZB130

Analogue (Position control)



8 x 32 x 8	26 x 26 x 13	40 x 40 x 15	80 x 80 x 26	M12	M18	M30
5 mm	10 mm	15 mm	40 mm	M: 2 mm / P: 4 mm	M: 5 mm / P: 8 mm	M: 10 mm / P: 15 mm
1...4	1...10	2...15	5...40	M: 0.2...2 / P: 0.4...4	M: 0.5...5 / P: 0.8...8	M: 1...10 / P: 1.5...15
flush mountable	flush mountable	flush mountable	flush mountable	flush / non flush mountable	flush / non flush mountable	flush / non flush mountable
P	P	P	P	M or P	M or P	M or P
- 25...+ 60	- 25...+ 70	- 25...+ 70	- 25...+ 70	- 25...+ 70	- 25...+ 70	- 25...+ 70
pre-cabled: IP 68 (with connector: IP 67)				IP 67		
CE - UL - CSA - CCC - C-TICK						
15 x 32 x 8	26 x 26 x 13	40 x 40 x 15	80 x 80 x 26	Ø 12 x 50	Ø 18 x 50	Ø 30 x 52.5
-	-	-	-	-	-	-
-	-	-	-	-	-	-

-	-	-	-	-	-	-
-	-	-	-	-	-	-
-	-	-	-	-	-	-
XS9F111A1L2	XS9E111A1L2	XS9C111A1L2	XS9D111A1L2	XS4P12AB110	XS4P18AB110	XS4P30AB110
-	-	-	-	XS1M12AB120	XS1M18AB120	XS1M30AB120
XS9F111A2L2	XS9E111A2L2	XS9C111A2L2	XS9D111A2L2	-	-	-
-	-	-	-	XS4P12AB120	XS4P18AB120	XS4P30AB120
M8 or M12 connector						
-	-	-	-	-	-	-
-	-	-	-	-	-	-
XS9F111A1L01M8 (4)	XS9E111A1L01M12 (4)	XS9C111A1L01M12 (4)	XS9D111A1M12	-	-	-
XS9F111A2L01M8 (4)	XS9E111A2L01M12 (4)	XS9C111A2L01M12 (4)	XS9D111A2M12	-	-	-
10...36	10...36	10...36	10...36	10...38	10...38	10...38
-	-	-	-	-	-	-
-	-	-	-	-	-	-
± 1 V for 0...10 V version / ± 2 mA for 4...20 mA version						
-	-	-	-	-	-	-
-	-	-	-	-	-	-
2000	1000	1000	100	1500	500	300

(1) 6...150 and 6000 impulses/min for XSAV11373 and XSAV11801 (slow version); 120...3000 and 48000 impulses/min for XSAV12373 and XSAV12801 (fast version).



(2) For these sensors without short-circuit protection, it is essential to connect a 0.4 A quick-blow fuse in series with the load.

(3) Flying lead (L = 0.15 m) with end mounted remote control incorporating M12 connector.

(4) Flying lead (L = 0.15 m) with end connector.

(5) Flying lead (L = 0.15 m) with end mounted remote control incorporating 1/2"-20 UNF connector.

Accessories

PUR pre-wired connectors (1)		M8 (3 pin)		1/2"		M12 (4 pin)				
		Straight	Elbowed		Straight	Elbowed	Straight	Elbowed	Elbowed PNP LED	
 Straight  Elbowed	2 m	XZCP0566L2	XZCP0666L2	2 m	XZCP1865L2	XZCP1965L2	2 m	XZCP1141L2	XZCP1241L2	XZCP1340L2
	5 m	XZCP0566L5	XZCP0666L5	5 m	XZCP1865L5	XZCP1965L5	5 m	XZCP1141L5	XZCP1241L5	XZCP1340L5
	10 m	XZCP0566L10	XZCP0666L10	10 m	XZCP1865L10	XZCP1965L10	10 m	XZCP1141L10	XZCP1241L10	XZCP1340L10

(1) For PVC cable see page 47

Suitable female plug-in connectors

M8	Straight	Elbowed
Steel ring	XZCC8FDM30S	XZCC8FCM30S
M12 (4 pin)		
Steel ring	XZCC12FDM40B	XZCC12FCM40B
Plastic ring	XZCC12FDP40B	XZCC12FCP40B



Type	M12	M18	Ø 18 plain	M30
Nominal sensing distance Sn	7 mm	12 mm	12 mm	22 mm
Operating zone (mm)	0 ... 5.6	0 ... 9.6	0 ... 9.6	0 ... 17.6
Suitability for flush mounting (metal environment)	non flush mountable			
Case M (metal) (1)	M stainless steel 316 L			
Product certification	CE - UL - CSA - CCC - C-TICK			
Temperature range (°C)	- 25...+ 85			
Degree of protection (conforming to IEC 60529)	pre-cabled: IP 68 (with connector: IP 67) and IP 69K conforming to DIN 40050			

Sensors for DC applications (solid-state output: transistor)

Connection			Pre-cabled, non poisonous PVC (2 m)			
Dimensions (mm)			M12 x 55	M18 x 60	Ø 18 x 60	M30 x 62
3-wire	PNP	NO function	XS212SAPAL2	XS218SAPAL2	XS2L2SAPAL2	XS230SAPAL2
	NPN	NO function	XS212SANAL2	XS218SANAL2	XS2L2SANAL2	XS230SANAL2
Connection			M12 connector			
Dimensions (mm)			M12 x 61	M18 x 70	Ø 18 x 70	M30 x 70
3-wire	PNP	NO function	XS212SAPAM12	XS218SAPAM12	XS2L2SAPAM12	XS230SAPAM12
	NPN	NO function	XS212SANAM12	XS218SANAM12	XS2L2SANAM12	XS230SANAM12
Supply voltage limits, min./max. (V) including ripple			10...36			
Switching capacity, max. (mA)			≤ 200			
Switching frequency (Hz)			2500	1000	1000	500
Short-circuit protection (★) / LED output state indicator (⊗)			★ / ⊗	★ / ⊗	★ / ⊗	★ / ⊗
Voltage drop, closed state (V) at I nominal			≤ 2			

Multi-current/multi-voltage sensors for AC/DC applications

Connection			Pre-cabled, non poisonous PVC (2 m)			
Dimensions (mm)			–	M18 x 60	–	M30 x 62
2-wire (2)	AC/DC	NO function	–	XS218SAMAL2	–	XS230SAMAL2
Connection			1/2"-20 UNF connector			
Dimensions (mm)			–	M18 x 72	–	M30 x 74
2-wire (2)	AC/DC	NO function	–	XS218SAMAU20	–	XS230SAMAU20
Supply voltage limits, min./max. (V) 50-60 HZ			–	20 ... 264	–	20 ... 264
Switching capacity, max. (mA)			–	300 AC / 200 DC	–	300 AC / 200 DC
Switching frequency (Hz)			–	25 AC / 1000 DC	–	25 AC / 300 DC
LED output state indicator (⊗)			–	⊗	–	⊗
Voltage drop, closed state (V) at I nominal			–	≤ 5.5	–	≤ 5.5
Residual current, open state (mA)			–	≤ 0.8	–	≤ 0.8



(1) Plastic range available. M12, M18, M30:
To order, replace the second letter **S** in the reference by **A**
(example: XS212SAPAL2 becomes XS212AAPAL2).

(2) For these sensors without short-circuit protection, it is essential to connect a 0.4 A quick-blow fuse in series with the load.

Accessories

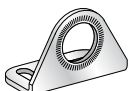
Fixing clamps		M12 pre-wired connector	M12 jumper cable
Plastic 	fixing centres 24.1 mm, with locking screw	female, 4-pin, stainless steel clamping ring	male, 3-pin, stainless steel clamping ring
	for sensor Ø 18 plain XUZB2005	Straight connector 5 m cable XZCPA1141L5	Straight connector 5 m XZCRA151140A5
Stainless steel 	for sensor	Elbowed connector 5 m cable XZCPA1241L5	1/2" pre-wired connector
	Ø 12 XSZBS12		Straight 5 m XZCP1865L5
	Ø 18 XUZA118		Elbowed 5 m XZCP1965L5
	Ø 30 XSZBS30		

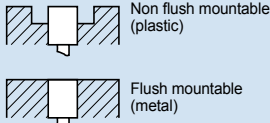

Suitability for flush mtg.		M12	M18	M30	Ø 32	40 x 40 x 117
Nominal sensing distance Sn	flush mountable	2 mm	5 mm	10 mm	15 mm	15 mm
	non flush mountable	—	8 mm	15 mm	20 mm	—
Operating zone Sa (mm) (2)	flush mountable	0...1.44	0...3.6	0...7.2	0...10	0...11
	non flush mountable	—	0...5.8	0...11	0...15	—
Case M (metal) P (plastic)	flush mountable	M	M	M	M	P
	non flush mountable	—	P	P	P	—
Product certification		CE				CE - UL - CSA
Temperature range (°C)		- 25...+ 70				
Degree of protection (conforming to IEC 60529)		IP 67				
Dimensions (mm) Ø x L or H x W x D		M12 x 70	M18 x 80	M30 x 80	M32 x 80	117 x 40 x 40

Sensors for DC applications

Connection				Pre-cabled, PVC (2 m)				
3-wire	PNP	NO function	flush mountable	XT112S1PAL2	XT118B1PAL2	XT130B1PAL2	—	—
			non flush mountable	—	XT218A1PAL2	XT230A1PAL2	—	—
	NO + NC functions	flush mountable	XT112S1PCL2	XT118B1PCL2	XT130B1PCL2	—	—	
		non flush mountable	—	—	—	—	—	
NPN	NO function	flush mountable	XT112S1NAL2	XT118B1NAL2	XT130B1NAL2	—	—	
		non flush mountable	—	XT218A1NAL2	XT230A1NAL2	—	—	
Connection				M12 connector				Screw terminals
3-wire	PNP	NO + NC functions	flush mountable	XT112S1PCM12	XT118B1PCM12	XT130B1PCM12	—	XT7C40PC440 (3)
			non flush mountable	—	XT218A1PCM12	XT230A1PCM12	—	—
	NPN	NO + NC functions	flush mountable	—	—	—	—	XT7C40NC440 (3)
Supply voltage limits, min./max. (V) including ripple				10...38				10...58
Switching capacity, max. (mA)				200				200
Short circuit-protection (★) / LED output state indicator (⊗)				★ / ⊗				★ / ⊗
Voltage drop, closed state (V) at I nominal				≤ 2				≤ 2
Switching frequency (Hz)				300	100 (XT2) / 200 (XT1)	100 (XT2) / 150 (XT1)	—	100

Multi-current/multi-voltage sensors for AC applications

Connection				Pre-cabled, PVC (2 m)				
2-wire AC (1)	NO function	flush mountable	—	XT118B1FAL2	XT130B1FAL2	XT132B1FAL2	—	
		non flush mountable	—	XT218A1FAL2	XT230A1FAL2	XT232A1FAL2	—	
	NC function	flush mountable	—	XT118B1FBL2	XT130B1FBL2	XT132B1FBL2	—	
		non flush mountable	—	—	XT230A1FBL2	XT232A1FBL2	—	
Connection				Screw terminals				
2-wire AC (1)	NO or NC programmable	flush mountable	—	—	XT230A2MDB (4)	—	XT7C40FP262	
Supply voltage limits, min./max. (V) 50-60 Hz				—	20...264	20...264	20...264	20...264
Switching capacity, max. (mA)				—	300	—	350	
LED output state indicator (⊗) / Power on LED (⊗)				⊗ / —				
Voltage drop, closed state (V) at I nominal				—	≤ 5.5	≤ 5.5	≤ 9	≤ 5.5
Switching frequency (Hz)				—	25	25	25	25

(1) For these sensors without short-circuit protection, it is essential to connect a 0.4 A quick-blow fuse in series with the load.

(2) The operating distance depends on the object material.

(3) Only for detecting insulating materials.

(4) 24...240 VAC or 24 VDC supply (non flush mountable)

Accessories

Suitable female plug-in connectors, including PUR pre-wired versions (1)

length 5 m without LED	pre-wired, elbowed	pre-wired, straight	screw terminal
M12	XZCP1241L5	XZCP1141L5	XZCC12FCM40B

(1) For PVC cable see page 47

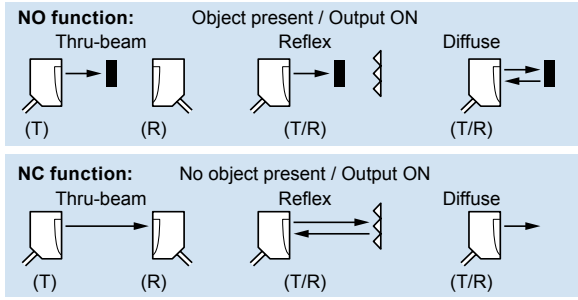

			M18 Metal (1) Cable	M12 connector	M18 Plastic Cable	M12 connector
Diffuse	Sensing distance		0.6 m (2) (3)		0.6 m (2) (3)	
	Output type	DC3 NO PNP	XUB5BPANL2	XUB5BPANM12	XUB5APANL2	XUB5APANM12
		NPN	XUB5BNANL2	XUB5BNANM12	XUB5ANANL2	XUB5ANANM12
	AC/DC 1C/O relay	-	-	-	-	
Reflex Polarised	Sensing distance (4)		2 m		2 m	
	Output type	DC3 NO PNP	XUB9BPANL2	XUB9BPANM12	XUB9APANL2	XUB9APANM12
		NPN	XUB9BNANL2	XUB9BNANM12	XUB9ANANL2	XUB9ANANM12
	AC/DC 1C/O relay	-	-	-	-	
Reflex	Sensing distance (4)		4 m		4 m	
	Output type	DC3 NO PNP	XUB1BPANL2	XUB1BPANM12	XUB1APANL2	XUB1APANM12
		NPN	XUB1BNANL2	XUB1BNANM12	XUB1ANANL2	XUB1ANANM12
	AC/DC 1C/O relay	-	-	-	-	
Thru beam	Sensing distance		15 m		15 m	
	Output type	DC3 NO PNP	XUB2BPANL2R	XUB2BPANM12R	XUB2APANL2R	XUB2APANM12R
		NPN	XUB2BNANL2R	XUB2BNANM12R	XUB2ANANL2R	XUB2ANANM12R
	AC/DC 1C/O relay	-	-	-	-	
Output function	NO		A	A	A	A
	NC		B	B	B	B
Thru beam Transmitter	DC		XUB2BKSNL2T	XUB2BKSNM12T	XUB2AKSNL2T	XUB2AKSNM12T
	AC/DC		-	-	-	-
Multimode	Sensing distance		Background suppression: 0.12 m - Diffuse: 0.3 m Reflex polarised: 3 m - Thru beam: 20 m			
	Output type	DC3 NO/NC PNP	XUB0BPSNL2	XUB0BPSNM12	XUB0APSNL2	XUB0APSNM12
		NPN	XUB0BNSNL2	XUB0BNSNM12	XUB0ANSNL2	XUB0ANSNM12
		PNP/NPN	-	-	-	-
	AC/DC 1C/O relay	-	-	-	-	
Thru beam Transmitter	DC		XUB0BKSNL2T	XUB0BKSNM12T	XUB0AKSNL2T	XUB0AKSNM12T
	AC/DC		-	-	-	-

(1) Brass metal, available also in stainless steel, see page food/beverage processing series

(2) For a sensing distance 0,1 m without sensitivity adjustment, change digit 5 by 4 into the reference (ex: XUB5BPANL2 becomes XUB4BPANL2)

Fixing	M18 x1	M18 x1
Dimensions	M18 x 64 mm / M18 x 78 mm	
Product certifications	CE, UL, CSA, C-Tick	CE, UL, CSA, C-Tick
DC common characteristics		
Supply voltage limits, min./max. (V) including ripple	10...36	10...36
Switching frequency (Hz)	500	500
Common characteristics for DC versions	Switching capacity, max. (mA): 100 / Overload and short-circuit protection (★) / LED output state	
AC/DC common characteristics		
Supply voltage limits, min./max. (V) including ripple	-	-
Switching frequency (Hz)	-	-
LED output state indicator (⊗) / power on LED (⊗)	-	-

Accessories

Reflectors

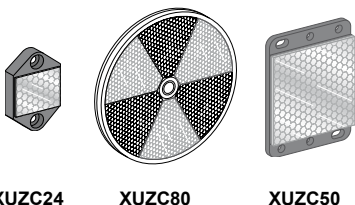

Reflectors (mm)	
Ø 21	XUZC21
24 x 21	XUZC24
11 x 33	XUZC08
Ø 39	XUZC39
Ø 80	XUZC80
50 x 50	XUZC50
100 x 100	XUZC100

3D fixings with ball joint



Bracket with ball joint for sensors and reflector XUZC50



Protective housing with ball joint

for	
XUB...	XUZZ2003
XUM0...	XUZZM2003
XUK...	XUZZK2003
XUX...	XUZZX2003

for	
XUK...	XUZZK2004
XUX...	XUZZX2004

M12 rod for ball joint

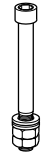

XUZZ2001



Miniature Cable		M8 connector	Compact 50 x 50 mm		Compact 92 x 71 mm	
			Cable	M12 connector	Screw terminal	M12 connector
1 m (3)			1 m (3)		2.1 m (3)	
XUM5APCNL2	XUM5APCNM8	XUM5AP ANL2	XUK5AP ANM12	XUX5AP ANT16	XUX5AP ANM12	
XUM5ANCNL2	XUM5ANCNM8	XUK5AN ANL2	XUK5AN ANM12	XUX5AN ANT16	XUX5AN ANM12	
-	-	XUK5ARCNL2	-	XUX5ARCNT16	-	
5 m (3)			5 m		11 m (3)	
XUM9APCNL2	XUM9APCNM8	XUK9AP ANL2	XUK9AP ANM12	XUX9AP ANT16	XUX9AP ANM12	
XUM9ANCNL2	XUM9ANCNM8	XUK9AN ANL2	XUK9AN ANM12	XUX9AN ANT16	XUX9AN ANM12	
-	-	XUK9ARCNL2	-	XUX9ARCNT16	-	
-	-	7 m		14 m (3)		
-	-	XUK1AP ANL2	XUK1AP ANM12	XUX1AP ANT16	XUX1AP ANM12	
-	-	XUK1AN ANL2	XUK1AN ANM12	XUX1AN ANT16	XUX1AN ANM12	
-	-	XUK1ARCNL2	-	XUX1ARCNT16	-	
15 m (3)			30 m		40 m (3)	
XUM2APCNL2R	XUM2APCNM8R	XUK2AP ANL2R	XUK2AP ANM12R	XUX2AP ANT16R	XUX2AP ANM12R	
XUM2ANCNL2R	XUM2ANCNM8R	XUK2AN ANL2R	XUK2AN ANM12R	XUX2AN ANT16R	XUX2AN ANM12R	
-	-	XUK2ARCNL2R	-	XUX2ARCNT16R	-	
	NO or NC		A	A	A	A
			B	B	B	B
XUM2AKCNL2T	XUM2AKCNM8T	XUK2AKSNL2T	XUK2AKSNM12T	XUX0AKSAT16T	XUX0AKSAM12T	
-	-	XUK2ARCNL2T	-	XUX0ARCTT16T	-	
Background suppression: 0.1 m - Diffuse: 0.4 m		Background suppression: 0.28 m - Diffuse: 0.8 m		Background suppression: 1.3 m - Diffuse: 2 m		
Reflex polarised: 3 m - Thru beam: 10 m		Reflex polarised: 4 m - Thru beam: 30 m		Reflex polarised: 11 m - Thru beam: 40 m		
XUM0APSAL2	XUM0APSAM8	-	-	-	-	
XUM0ANSAL2	XUM0ANSAM8	-	-	-	-	
-	-	XUK0AKSAL2	XUK0AKSAM12	XUX0AKSAT16	XUX0AKSAM12	
-	-	XUK0ARCTL2	-	XUX0ARCTT16	-	
XUM0AKSAL2T	XUM0AKSAM8T	XUK0AKSAL2T	XUK0AKSAM12T	XUX0AKSAT16T	XUX0AKSAM12T	
-	-	XUK0ARCTL2T	-	XUX0ARCTT16T	-	

(3) With sensitivity adjustment

(4) With reflector XUZC50 to be ordered separately

Direct fixing centres 25.5, M3 screws 12 x 34 x 20 CE, UL, CSA, C-Tick	Direct fixing centres 40 x 40, M4 screws 18 x 50 x 50 CE, UL, CSA, CCC, C-Tick	Direct fixing centres 30/38 to 40/50/74, M5 screws 30 x 92 x 71 CE, UL, CSA, CCC, C-Tick
10...30	10...30	10...36
1000	500	500
indicator (⊗): yes / power on LED (⊗): yes		
-	20...264	20...264
-	20	20
-	⊗ / ⊗	⊗ / ⊗

Simple fixings

Fixing support for M12 rod

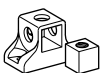

XUZ2003

Single bracket

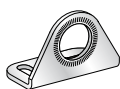

for	standard	with ball joint
XUB...	XUZA118 (stnls. steel)	XUZA218 (plastic)
XUM...	XUZAM02	-
XUK...	XUZA51	-
XUX...	XUZX2000	-

Suitable female plug-in connectors, including PUR pre-wired versions (1)

length 5 m

without LED

M8

M12



pre-wired, elbowed

XZCP1041L5

XZCP1241L5

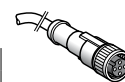

pre-wired, straight

XZCP0941L5

XZCP1141L5



screw terminal

XZCC8FCM40S

XZCC12FCM40B

(1) For PVC cable see page 47

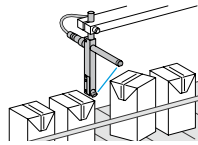
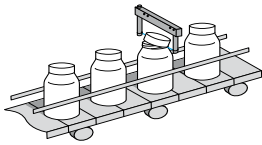

System	Thru-beam with modular red LED light source
Sensing distance	30...150 mm
Minimum size of objet detected	0,8 mm
Case M (metal)	M
Temperature range (°C) / Degree of protection (conforming to IEC 60529)	- 10...+ 60 / IP65 & IP67
Product certification	CE - cULus

Sensors for DC applications (solid-state output: transistor)

Connection		M8 connector 3-pin				Pre-cabled L = 2 m.						
Dimensions (mm)			A	B	C	D		A	B	C	D	
Transmitter / Receiver 3 wire NO function PNP 												
Output function	NO	A										
	NC	B										
Supply voltage limits, min./max. (V) including ripple	10...30											
Switching capacity, max. (mA) / Switching frequency (Hz)	100/4kHz											
Overload and short-circuit protection (★) / LED output state indicator (⊗)	★ / ⊗											



System	Thru-beam with infrared emission				
Passageway dimensions	30 x 30 mm	60 x 60 mm	200 x 120 mm	200 x 180 mm	200 x 250 mm
Connection	M8 (4 pin)		M12 (4 pin)		
Minimum size of object to be detected	∅ 2 mm	XUVF30M8	XUVF60M8	-	-
	∅ 4 mm	-	-	XUVF120M12	XUVF180M12
	∅ 10 mm	-	-	XUYFRS120S	XUYFRS180S
Type and output function	4-wire, PNP and NPN Output function ON or OFF on passage of object, programmable				
Function type	Dynamic (XUVF30M8, XUVF60M8), Dynamic or static (XUVF120M12, XUVF180M12, XUVF250M12)				
Supply voltage limits, min./max. (V) including ripple	18...30				
Switching capacity, max. (mA) / Switching frequency (Hz)	≤ 100 mA / 500 Hz				
Overload and short-circuit protection (★) / LED output state indicator (⊗)	★ / ⊗				

Accessories

Suitable female PUR pre-wired plug-in connectors (1)



Straight

Elbowed

	M8 (3 pin)		M8 (4 pin)		M12 (4 pin)	
	For optical forks without setting		For optical forks and frame with setting		For frame with setting	
	Straight	Elbowed	Straight	Elbowed	Straight	Elbowed
2 m	XZCP0566L2	XZCP0666L2	XZCP0941L2	XZCP1041L2	XZCP1141L2	XZCP1241L2
5 m	XZCP0566L5	XZCP0666L5	XZCP0941L5	XZCP1041L5	XZCP1141L5	XZCP1241L5

(1) For PVC cable see page 47

Forks with teach mode (1)



System, with teach mode	Thru-beam	Thru-beam laser
Sensing distance	2...120 mm	2...120 mm
Fixing (mm)	(see column E below)	
Minimum size of objet detected	0,2 mm	0,05 mm
Case M (metal) / Setting-up assistance LEDs ☒	M / ☒	
Temperature range (°C) / Degree of protection (conforming to IEC 60529)	- 25...+ 60 / IP 65	
Product certification	CE - cULus	

Sensors for DC applications (solid-state output: transistor)

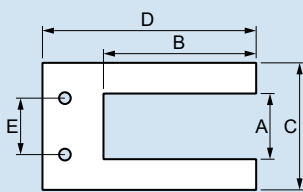
Connection	M8 connector - 4 Pin									
Type of output	3-wire PNP/NPN programmable NO/NC									
Dimensions (mm)	A	B	C	D	E	A	B	C	D	E
Transmitter / Receiver										
										
XUYFANEP40002	2	42	32	57	14	XUYFALNEP40002	2	42	41	57
XUYFANEP60002	2	59		77		XUYFALNEP60002	2	59		77
XUYFANEP100002	2	95		110		XUYFALNEP100002	2	95		110
XUYFANEP40005	5	42	35	57	14	XUYFALNEP40005	5	42	44	57
XUYFANEP60005	5	59		77		XUYFALNEP60005	5	59		77
XUYFANEP100005	5	95		110		XUYFALNEP100005	5	95		110
XUYFANEP40015	15	42	45	57	27	XUYFALNEP40015	15	42	54	57
XUYFANEP60015	15	59		77		XUYFALNEP60015	15	59		77
XUYFANEP100015	15	95		110		XUYFALNEP100015	15	95		110
XUYFANEP40030	30	42	60	57	42	XUYFALNEP40030	30	42	69	57
XUYFANEP60030	30	59		77		XUYFALNEP60030	30	59		77
XUYFANEP100030	30	95		110		XUYFALNEP100030	30	95		110
XUYFANEP40050	50	42	80	57	40	XUYFALNEP40050	50	42	89	57
XUYFANEP60050	50	59		77		XUYFALNEP60050	50	59		77
XUYFANEP100050	50	95		110		XUYFALNEP100050	50	95		110
XUYFANEP40080	80	42	110	57	70	XUYFALNEP40080	80	42	119	57
XUYFANEP60080	80	59		77		XUYFALNEP60080	80	59		77
XUYFANEP100080	80	95		110		XUYFALNEP100080	80	95		110
XUYFANEP40120	120	42	150	57	110	XUYFALNEP40120	120	42	159	57
XUYFANEP60120	120	59		77		XUYFALNEP60120	120	59		77
XUYFANEP100120	120	95		110		XUYFALNEP100120	120	95		110
Supply voltage limits, min./max. (V) including ripple	10...30					10...30				
Switching capacity, max. (mA) / Switching frequency (Hz)	100/10 kHz					100/10 kHz				
Overload and short-circuit protection (★) / LED output state indicator (☒)	★ / ☒					★ / ☒				

(1) To order a fork without teach mode, delete **A** of the reference. Ex: XUYFANEP40002 becomes XUYFNEP40002



System	Ultrasonic thru-beam	Thru-beam
	Special transparent labels	For all other opaque labels
Sensing distance	XUVU06M3PSNM8	XUVE04M3PSNM8
Switching frequency (Hz)	1500	10 000
Sensitivity adjustment	numeric potentiometer (1)	numeric potentiometer (1)
Connection	M8 (4 pin)	
Case M (metal) / Setting-up assistance LEDs ☒	M / ☒	
Temperature range (°C) / Degree of protection (conforming to IEC 60529)	+5...+ 55 / IP 65	- 20...+ 60 / IP 65
Product certification	CE	CE - cULus

(1) : remote adjustment available.

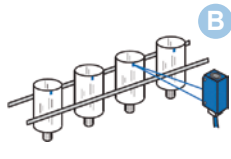
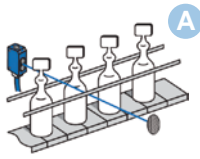

Accurate detection
or very long sensing
distance



Robustness
and compactness



A



B

Application	Thru-beam	Diffuse	Reflex	Diffuse contrast
System				
Sensing distance	100 m (2)	0.07 m	10...1000 mm (3)	40...150 mm
Fixing (mm)	M18 x 1	M8 x 1	Direct, 2 M3 holes, fixing centres 24 mm	
Sensitivity adjustment	Teach mode	–	Teach mode	
Case M (metal) P (plastic) / Setting-up assistance LEDs ☒	P / ☒	M / –	P	
Temperature range (°C) / Degree of protection (conforming to IEC 60529)	- 10...+ 45°C	- 25...+ 55	- 20...+ 60°C	
Degree of protection (conforming to IEC 60529)	IP 67	IP 67	IP 67	
Product certification	CE - UL - CSA	CE - cULus	CE - cULus	
Dimensions (mm) Ø x L or H x W x D	Ø 18 x 64	Ø 8 x 40	35.8 x 12 x 20	

Sensors for DC applications (solid-state output: transistor)

Connection	Pre-cabled	M12	PVR (2 m)		
Transmitter / Receiver	3-wire PNP NO function	–	XUAH0515	–	–
Connection	Connector	M12	M8 4-pin		
Transmitter / Receiver	3-wire PNP NO function	–	XUAH0515S	–	–
	3-wire PNP programmable NO / NC	XUBLAPCNM12	–	XUYBC0929LSP	XUYPCCO929LSP
	3-wire NPN programmable NO / NC	XUBLANCNM12	–	–	–
Supply voltage limits, min./max. (V) including ripple	10...30	10...30	10...30	10...30	10...30
Switching capacity, max. (mA) / Switching frequency (Hz)	100 / 1500	100 / 700	100 / 1000	100 / 1000	100 / 1000
Overload and short-circuit protection (★) / LED output state indicator (☒)	★ / ☒	★ / ☒	★ / ☒	★ / ☒	★ / ☒

(1) Reflex and thru-beam systems also available.

(2) or min. size of object: 0.2 mm

(3) With specific reflector XUY1111, format 50 x 50 mm. To be ordered separately.

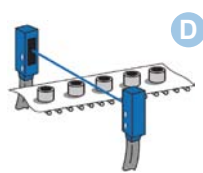
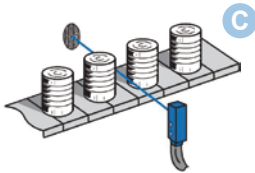

Miniature series sensors



compact 50x50mm



Laser class II



Laser class II

Application	Polarised reflex	Thru-beam	Polarised reflex	Thru beam	Back ground suppression	Diffuse
System						
Sensing distance	1...1.5 m (4)	4 m	12 m (7)	25 m	0.8 m	1.2 m
Fixing (mm)	2 x Ø 3 holes / fixing centres 9.5		2 x Ø 4.3 holes / fixing centres 30			
Sensitivity adjustment	Potentiometer	Potentiometer	Teach mode	Teach mode	potentiometer	Teach mode
Case P (plastic) / Setting-up assistance LEDs ☒	P / ☒					
Temperature range (°C) / Degree of protection (conforming to IEC 60529)	0...+ 50°C / IP 65 & IP 67		-20...+ 60°C / IP67 & IP69K			
Product certification	CE - cULus		CE, Ecolab			
Dimensions (mm) H x W x D	40 x 10 x 13.5		50 x 50 X 23			

Sensors for DC applications (solid-state output: transistor)

Connection	M8 connector (5) - 4 Pin	M12 connector - 4 pin				
	PNP NO function	XUYBC0989SP	XUYRC0989SP	–	–	–
	NPN NO function	XUYBC0989SN	XUYRC0989SN	–	–	–
	PNP programmable NO / NC			XUK9LAPSM12 (6)	XUK2LAPSM12R (6)	XUK8LAPPNM12 (6)
Transmitter	–	XUYECO989	–	XUK2LAKSM12T (6)	–	–
Supply voltage limits, min./max. (V) including ripple	10...30		12...30			
Switching capacity, max. (mA) / Switching frequency (Hz)	100 / 500		100 / ≤ 2000	100 / ≤ 3500	100 / ≤ 1000	100 / ≤ 600
Overload and short-circuit protection (★) / LED output state indicator (☒)	★ / ☒					

(4) 50 x 50 reflector included.

(5) For 2 m pre-cabled version, delete **CO** from the reference. (Example: XUYBC0989SP becomes XUYB989SP or XUYRC0989SP becomes XUYR989SP).

(6) Fixing bracket: XUZA51S to be ordered separately

(7) With reflector XUZC50HP to be ordered separately

Materials handling series - Conveying Analogue output

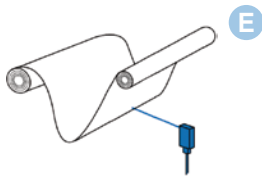

Analogue output
Position control

High access
gain for resistance
to accumulation of dirt

Application	E			E	
System	Diffuse	Reflex	Diffuse	Diffuse	Thru-beam
Sensing distance	0.20...0.80 m	0.20...30 m (1)	0.20...6 m (2)	0.05...0.40 m	50 m
Fixing (mm)	fixing ctrs: 30 - 11P cable gland	3 trous 5,8mm		M18 x 1	M18 x 1
Sensitivity adjustment	-	Teach mode		Potentiometer	Potentiometer
Case M (metal) P (plastic) / Setting-up assistance LEDs ⊗	P / ⊗	P / ⊗		M / ⊗	M / ⊗
Temperature range (°C) / Degree of protection (conforming to IEC 60529)	- 25...+ 60 / IP 67	- 20...+ 50 / IP67		- 25...+ 55 / IP 67	- 25...+ 55 / IP 67
Product certification	CE - UL - CSA	CE, cULus		CE - UL - CSA	CE - UL - CSA - C-TICK
Dimensions (mm) Ø x L or H x W x D	86 x 27 x 83	93 x 42 x 95		M18 x 95	M18 x 95

Sensors for DC applications

Connection	Screw terminals	M12 connector - 5 pins	M12 connector	M12 connector
Transmitter / Receiver				
analogue 4-20 mA / 0-10 V	XUJK803538 (3)	-	-	-
analogue 4-20 mA	-	-	XU5M18AB20D	-
analogue 4-20mA + 1 PNP	-	-	-	XU2M18AP20D (2)
analogue 4-20mA + 2 PNP	-	XUE1AA2NM12	XUE5AA2NM12	-
Supply voltage limits, min./max. (V) including ripple	20...30	18...30	10...30	10...30
Switching capacity, max. (mA) / Switching frequency (Hz)	max: 20, min: 4 / 10000	100 / 38 (fast mode), 16 (slow mode)	max: 20, min: 4 / 20	100 / 30
Overload and short-circuit protection (★) / LED output state indicator (⊗)	★ / ⊗	★ / ⊗	★ / ⊗	★ / ⊗

(1) with reflector XUZC250 to be ordered separately.

(2) on white and grey object 0,2 ... 6m, on black object 0,2 ... 2,5m

(3) With 3-wire PNP output.

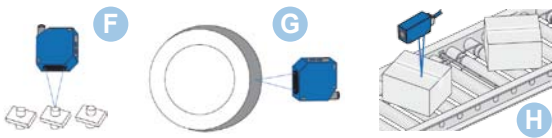

Application	F G		H
System	Diffuse, analogue output		Diffuse
	0-10 V	4-20 mA	
Sensing distance	40...60 mm	80...300 mm	0...100 mm
Minimum size of object	1 mm	1.5 x 3.5 mm	85 mm
Fixing (mm)	direct: 3 M4 holes, fixing centres 40 mm		direct on conveyor with specific fixing parts
Sensitivity adjustment	Potentiometer		No
Case P (plastic) / Setting-up assistance LEDs ⊗	P / ⊗		Aluminium tube / x
Temperature range (°C)	0...+ 45°		- 25...+ 55°
Product certification	CE - cULus		CE - UL
Dimensions (mm) H x W x D	50 x 17 x 50		Tube Ø 12 , variable length from 200 to 900 mm (example 415 mm)

Sensors for DC applications (solid-state output: transistor)

Connection	M12 connector	M12 connector	Remote M12 connector
Transmitter / Receiver 0...10 V	XUYPC0925L1ANSP	XUYPC0925L3ANSP	XUY415N4HL03M12
Supply voltage limits, min./max (V) including ripple	18...28		18...30
Switching capacity, max.	3 mA / 0...10 V analogue output	3 mA / 4...20 mA analogue output	100 mA
Switching frequency (Hz)	40		1000
Overload and short-circuit protection (★) / LED output state indicator (⊗)	★ / ⊗		★ / ⊗

Accessories

Suitable female PUR pre-wired plug-in connectors (1) Female connectors Fixing for XUE

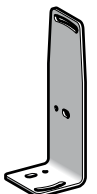
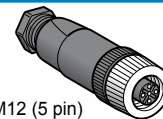
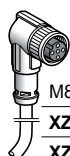
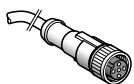

M8 straight	M12 straight	M8 elbowed	M12 elbowed	M12 (5 pin)	
2 m XZCP0941L2	XZCP1141L2	XZCP1041L2	XZCP1241L2	straight XZCC12FCM50B	For compact
5 m XZCP0941L5	XZCP1141L5	XZCP1041L5	XZCP1241L5	elbowed XZCC12FDM50B	XUZA618

(1) For PVC cable see page 47

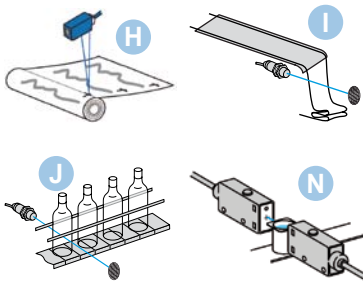

Application	Contrast sensors		Colour sensors
System	Diffuse (with teach mode)	Diffuse (with teach mode)	Diffuse
Sensing distance	19 mm	9 mm (2)	0.02 m
Fixing (mm)	direct: fixing centres 40 x 40	direct: 21 x 28, M5 screws	direct: fixing ctrs. 40x40
Sensitivity adjustment	Teach button	Teach button	Teach button
Case M (metal) P (plastic) / Setting-up assistance LEDs ☉	P / ☉	M / ☉	P / ☉
Temperature range (°C) / Degree of protection (conforming to IEC 60529)	- 10...+ 55 / IP 65	- 10...+ 55 / IP 67	- 10...+ 55 / IP 65
Product certification	CE - cULus	CE	CE - cULus
Dimensions (mm) Ø x L or H x W x D	50 x 15 x 50	96 x 31 x 64	50 x 25 x 50

Sensors for DC applications (solid-state output: transistor)

Connection	M12 connector	M12 connector	M12 connector - 8 pin
Transmitter / Receiver			
3-wire PNP NO function	XUKR1PSMM12	-	XUKC1PSMM12
3-wire NPN NO function	XUKR1NSMM12	-	XUKC1NSMM12
3-wire PNP / NPN programmable NO / NC	-	XURK1KSMM12	-
Supply voltage limits, min./max. (V) including ripple	10...30	10...30	10...30
Switching capacity, max. (mA) / Switching frequency (Hz)	100 / 5000	200 / 10000	100 / 1500

(1) Nominal sensing distance 50 m. Use between 10 and 20 cm, depending on application.
 (2) 7 mm with XURZ02; 18 mm with XURZ01.

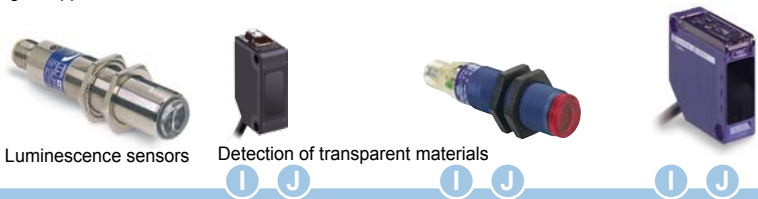

Application	Luminescence sensors			Detection of transparent materials	
System	Diffuse (manual)	Reflex (potentiometer)	Reflex (with teach mode) (50 x 50 reflector included)		
Sensing distance	0.02...0.08 m	0.1...2 m	0...1.4 m (4)		1.5 m
Fixing (mm)	M18 x 1	M3 holes, fixing centers 24	M18 x 1	direct: fixing ctrs. 40 x 40	
Sensitivity adjustment	Potentiometer	Potentiometer	Teach button		
Case M (metal) P (plastic) / Setting-up assistance LEDs ☉	M / ☉	P / ☉	P / ☉		
Temperature range (°C) / Degree of protection (conforming to IEC 60529)	- 25...+ 55 / IP 67	- 25...+ 55 / IP67	0...+ 55 / IP 67	- 25...+ 55 / IP 65	
Product certification	CE - CSA - UL	CE - cURus	CE - UL - CSA - C-TICK		
Dimensions (mm) Ø x L or H x W x D	Ø 18 x 95	33 x 20 x 11	Ø 18 x 64	50 x 18 x 50	

Sensors for DC applications (solid-state output: transistor)

Connection	Pre-cabled, PVC (2 m)			
Transmitter / Receiver				
3-wire PNP programmable NO / NC	-	XUMTAPCNL2	XUBTAPSNL2 (5)	-
3-wire NPN programmable NO / NC	-	XUMTANCNL2	XUBTANSNL2 (5)	-
3-wire PNP / NPN programmable NO / NC	-	-	-	XUKT1KSML2
Connection	M12 connector	M8 connector	M12 connector	M12 connector
Transmitter / Receiver				
3-wire PNP fonction NO	XU5M18U1D	-	-	-
3-wire PNP programmable NO / NC	-	XUMTAPCNM8 (3)	XUBTAPSNM12 (5)	-
3-wire NPN programmable NO / NC	-	XUMTANCNM8	XUBTANSNM12 (5)	-
3-wire PNP / NPN programmable NO / NC	-	-	-	XUKT1KSMM12
Supply voltage limits, min./max. (V) including ripple	10...30	10...30	10...32	10...30
Switching capacity, max. (mA) / Switching frequency (Hz)	100 / 1000	100 / 1000	100 / 1000	100 / 1500

(3) also available with M12 remote connector with 0.3 m cable : replace M8 by L03M12.
 (4) 0...0.8 m for versions with 90° head, to order replace the 8° digit N by W. Example XUBTAPSNL2 becomes XUBTAPSWL2
 (5) Also available in stainless steel for food and beverage processing applications. To order, replace the letter A by S in the ref. Example: XUBTAPSNL2 becomes XUBTSPSNL2.

Accessories

Suitable female plug-in connectors, including PUR pre-wired versions (1)			Lenses for colour mark	
L = 5 m, without LED	Wired, elbowed		Wired, straight	
M8 (or S) 4 pin	XZCP0666L5		XZCP0566L5	
M12 (or D) 4 pin	XZCP1241L5		XZCP1141L5	
M12 8 pin	-		XSZMCR03 (3 m)	
			Screw terminal	
			XZCC8FCM30S	
			XZCC12FCM40B	
				Lens for 18 mm sensing distance
				XURZ01
				Lens for 7 mm sensing distance
				XURZ02

(1) For PVC cable see page 47

Food/beverage processing series



Stainless steel version for resistance to harsh agents

Application	Stainless steel version for resistance to harsh agents		
System	Polarised reflex	Background suppression	Thru-beam
Sensing distance	0.4...11 m (1)	0.03...0.55 m	0...15 m
Fixing (mm)	2 x Ø 4.3 holes ...		
Case M (metal)	M (stainless steel 316L)		
Temperature range (°C) / Degree of protection (conforming to IEC 60529)	-20 ... +60°C (100°C for cleaning and sterilization phase whilst not in service) / IP67, IP69K		
Product certification	CE, Ecolab		
Dimensions (mm) H x W x D	50 x 50 X 23		

Sensors for DC applications (solid-state output: transistor)

Connection	M12 connector - 4 pin			
Transmitter / Receiver	4-wire PNP	XUK9SPSMM12	XUK8SPSMM12	XUK2SKSMM12T (transmitter) XUK2SPSMM12R (receiver)
Supply voltage limits, min./max. (V) including ripple	10...30			
Switching capacity, max. (mA) / Switching frequency (Hz)	100 / 600		100 / 400	

(1) With reflector XUZC100 to be ordered separately



Stainless steel version for resistance to harsh agents

System	Multimode (3)	Polarised reflex 50x50 mm reflector included (2)	Diffuse (2)	Thru-beam (2)
Sensing distance	(4)	3 / 2 m	0.15 / 0.10 m	20 / 15 m
Fixing (mm)	M18 x 1	M18 x 1	M18 x 1	M18 x 1
Case M (metal)	M (stainless steel)	M (stainless steel)	M (stainless steel)	M (stainless steel)
Temperature range (°C) / Degree of protection (conforming to IEC 60529)	- 25...+ 55 / IP 67			
Product certification	CE - UL - CSA - C-TICK			
Dimensions (mm) Ø x L	Ø 18 x 64	Ø 18 x 62	Ø 18 x 62	Ø 18 x 64

Sensors for DC applications (solid-state output: transistor)

Connection	Pre-cabled, PvR (2 m)						
Transmitter / Receiver	3-wire PNP	programmable NO / NC	XUB0SPSNL2	XU9N18PP341	XU5N18PP341	XU2N18PP341	
	3-wire NPN	programmable NO / NC	XUB0SNSNL2	XU9N18NP341	XU5N18NP341	XU2N18NP341	
Connection	M12 connector						
	Transmitter / Receiver	3-wire PNP	programmable NO / NC	XUB0SPSNM12	XU9N18PP341D	XU5N18PP341D	XU2N18PP341D
		3-wire NPN	programmable NO / NC	XUB0SNSNM12	XU9N18NP341D	XU5N18NP341D	XU2N18NP341D
Thru-beam transmitter accessory		pre-cabled (2 m)	XUB0SKSNL2T	-	-	-	
		connector	XUB0SKSNM12T	-	-	-	
Supply voltage limits, min./max. (V) including ripple	10...36		10...30		10...30		
Switching capacity, max. (mA) / Switching frequency (Hz)	100 / 250		100 / 500		100 / 500		

(2) Also available with 90° head. To order, add the letter **W** after the numbers 341 in the reference. Example: XU9N18PP341 becomes XU9N18PP341W or XU9N18PP341WD.

(3) Also available with 90° head, to order replace the 8° digit **N** by **W**. Example XUB0SPSNL2 becomes XUB0SPSWL2

(4) Background suppression: **0.12 m** - Diffuse: **0.3 m** - Reflex polarised: **3 m** - Thru beam: **20 m**

Accessories

Pre-wired connectors	Ecolab reflector 50x50 (2)	Stainless steel fixing bracket
L = 5 m		
Elbowed XZCPA1241L5		
Straight XZCPA1141L5	XUZC50CR	XUA118 (for M18)
		XUA51S (for compact)

(2) Sensing distance for XUK9S: 3m with XUZC50CR or 6m with XUZC50.



Application	K		P	K
System	Background suppression	Diffuse with background suppression		
		Sensing distance 1	Sensing distance 2	
Sensing distance	1.5...80 mm	10...60 mm	30...110 mm	
Minimum size of object	–	0.3 mm	0.7 mm	
Fixing (mm)	2 x Ø 3 holes / fvg. ctrs. 14.5	direct: 2 M3 holes, fixing centres 24 mm		
Sensitivity adjustment	Potentiometer	Teach mode		
Case P (plastic) / Setting-up assistance LEDs ☉	P / ☉	P		
Temperature range (°C) / Degree of protection (conforming to IEC 60529)	0...+ 50 / IP 65 & IP 67	- 20...+ 60°C / IP 67		
Product certification	CE - cULus	CE - cULus		
Dimensions (mm) H x W x D	32 x 13 x 20	35.8 x 12 x 20		

Sensors for DC applications (solid-state output: transistor)

Connection	M8 connector (1) - 4 Pin		M8 connector- 4 Pin	M8 connector- 4 Pin
Transmitter / Receiver	PNP	NO function	XUYPSO989SP	–
	NPN	NO function	XUYPSO989SN	–
	PNP	programmable NO / NC	–	XUYPSO929L1SP
Supply voltage limits, min./max. (V) including ripple	10...30		10...30	10...30
Switching capacity, max. (mA) / Switching frequency (Hz)	100 / 500		100 / 1000	100 / 1000
Overload and short-circuit protection (★) / LED output state indicator (☉)	★ / ☉		★ / ☉	★ / ☉

(1) For 2 m pre-cabled connection delete CO from the reference. Example: XUYPSO989SP becomes XUYPS989SP.

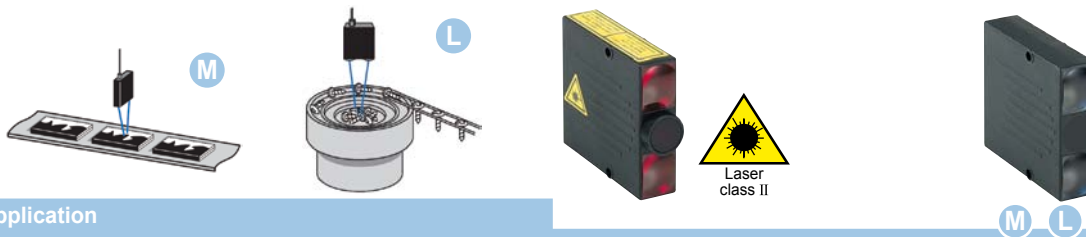

Application	M		L
System	Background suppression	Background suppression, 2 chnls.	
Sensing distance	50...300 mm	50...600 mm	
Minimum size of object	0.5 mm	–	
Fixing (mm)	direct: 2 M4 holes, ctrs. 54 mm	2 x Ø 4 holes, fixing ctrs. 54	
Sensitivity adjustment	Potentiometer	Potentiometer	
Case P (plastic) / Setting-up assistance LEDs ☉	P / ☉	P / ☉	
Temperature range (°C) / Degree of protection (conforming to IEC 60529)	0...+ 50 / IP 65	0...+ 60 / IP 40	
Product certification	CE - cULus	CE - cULus	
Dimensions (mm) H x W x D	60 x 18 x 60	60 x 18 x 60	

Sensors for DC applications (solid-state output: transistor). Sensors with overload and short-circuit protection

Connection	M8 connector	
Transmitter / Receiver	3-wire PNP / NPN	programmable NO / NC
Supply voltage limits, min./max. (V) including ripple	10...30	10...30
Switching capacity, max. (mA) / Switching frequency (Hz)	100 / 5000	100 / 370

Accessories

PUR Pre-wired connectors (1)							
M8 (4 pin)			M12 (4 pin)		7/8" (5 pin)		
	Straight	Elbowed	Straight	Elbowed	Straight		
2 m	XZCP0941L2	XZCP1041L2	2 m	XZCP1141L2	XZCP1241L2	2 m	XZCP1764L2
5 m	XZCP0941L5	XZCP1041L5	5 m	XZCP1141L5	XZCP1241L5	5 m	XZCP1764L5



Straight

Elbowed

(1) For PVC cable see page 47

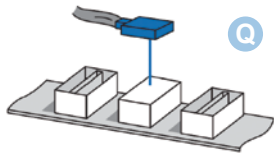

objects on conveyors



Application	Diffuse with adjustable background suppression		
System	Diffuse with adjustable background suppression		
Sensing distance	20...300 mm	0...1 m	2 m
Fixing (mm)	Fixing : M3 holes, fixing centers 24 mm	Direct fixing centres 40 x 40, M4 screws	Direct: fixing ctrs. 30/38 to 40/50/74 M5 screw
Sensitivity adjustment	potentiomètre	–	–
Case P (plastic) / Setting-up assistance LEDs ☉	P / ☉	P / ☉	P / ☉
Temperature range (°C) / Degree of protection (conforming to IEC 60529)	- 25...+ 55 / IP67	- 25...+ 55 / IP 65	- 25...+ 55 / IP 67
Product certification	CE- cURus	CE - UL - CSA	CE - UL - CSA
Dimensions (mm) H x W x D	33 x 20 x 11	50 x 18 x 50	92 x 30,5 x 71

Sensors for DC applications (solid-state output: transistor). Sensors with overload and short-circuit protection

Connection	Pre-cabled	Pre-cabled, PVC (2 m)	Screw terminals
Transmitter / Receiver		XUK8AKSNL2	XUX8AKSAT16 (3)
3-wire PNP / NPN programmable NO / NC	–		
PNP programmable NO / NC	XUM8APCNL2	–	–
NPN programmable NO / NC	XUM8ANCNL2	–	–
Connection	M8 connector	M12 connector	
Transmitter / Receiver		XUK8AKSNM12	XUX8AKSAM12
3-wire PNP / NPN programmable NO / NC	–		
PNP programmable NO / NC	XUM8APCNM8 (1)	–	–
NPN programmable NO / NC	XUM8ANCNM8	–	–
Supply voltage limits, min./max. (V) including ripple		10...36	10...36
Switching capacity, max. (mA) / Switching frequency (Hz)		100 / 250	100 / 150

(1) also available with M12 remote connector with 0.3 m cable : replace M8 by L03M12.



Système	Diffuse with adjustable background suppression		
Sensing distance	70...120 mm	10...750 mm	2 m
Fixing (mm)	M18 x 1	Direct fixing centres 40 x 40, M4 screws	Direct: fixing ctrs. 30/38 to 40/50/74 M5 screw
Sensitivity adjustment	Potentiometer	teach mode	–
Case M (metal) P (plastic) / Setting-up assistance LEDs ☉	M / ☉	P / ☉	P / ☉
Temperature range (°C) / Degree of protection (conforming to IEC 60529)	- 25...+ 55°C / IP 67	- 25...+ 55°C / IP 65	- 25...+ 55 / IP 67
Product certification	CE - UL - CSA	CE - UL - CSA	CE - UL - CSA
Dimensions (mm) Ø x L or H x W x D	M18 x 82	50 x 18 x 50	92 x 30,5 x 71

Multi-current/multi-voltage sensors for AC/DC applications

Connection	Cable L = 2m	Cable	Screw terminals
Transmitter / Receiver	XU8M18MA230	–	–
AC/DC			
NO function programmable NO / NC	–	XUK8ARCTL2	XUX8ARCTT16
Supply voltage limits, min./max. (V) including ripple	20...264	20...264	20...264
Switching capacity, max. (mA) / Switching frequency (Hz)	200 / 25	3000 / 20	3000 / 20
Overload and short-circuit protection (★) / LED output state indicator (☉)	(2) / ☉	–	–

(2) Sensor not short-circuit protected. Therefore, it is essential to connect a 0.4 A quick-blow fuse in series with the load.



	+/- potentiometer	Teach	Teach + Timer	Teach + Timer
Max. / usable sensing distance	Depending on fibre used, plastic only			
Fixing (mm)	DIN rail or direct: fixing centres 25, M3 screws			
Sensitivity adjustment	+/- numeric potentiometer	using teach mode	+/- numeric potentiometer	using teach mode
Case P (plastic) / Setting-up assistance LEDs ☉	P / ☉	P / ☉	P / ☉	P / ☉ and 4-digit display
Temperature range (°C) / Degree of protection (conforming to IEC 60529)	0...+60 / IP 65	-10...+55 / IP 65 (1)	0...+60 / IP 65	-10...+55 / IP 65 (1)
Product certification	CE - cULus	CE - cULus - cURus	CE - cULus	CE - cULus - cURus
Dimensions (mm) L x H x W	60 x 30 x 13	65 x 40 x 10	60 x 30 x 13	65 x 40 x 10

Sensors for DC applications (solid-state output: transistor)

Connection				Pre-cabled, PVC (2 m)			
References	3-wire PNP programmable	NO / NC	-	XUDA1PSML2	-	XUDA2PSML2	
Amplifier	3-wire NPN programmable	NO / NC	-	XUDA1NSML2	-	XUDA2NSML2	
Connection				M8 connector - 4 Pin			
References	3-wire PNP programmable	NO / NC	-	XUDA1PSMM8	-	XUDA2PSMM8	
Amplifier	3-wire NPN programmable	NO / NC	-	XUDA1NSMM8	-	XUDA2NSMM8	
	3-wire PNP/NPN programmable	NO / NC	XUYAFVCO966S (Glass) XUYAFPCO966S (Plastic)	-	XUYAFVCO946S (Glass) XUYAFPCO946S (Plastic)	-	
Supply voltage limits, min./max. (V) including ripple			10...30	10.8...26.4	10...30	10.8...26.4	
Switching capacity, max. (mA) / Switching frequency (Hz)			100 / 1000	100 / 1000	100 / 1000 time delayable	100 / 1000 time delayable	
Overload and short-circuit protection (★) / LED output state indicator (☉)			★ / ☉	★ / ☉	★ / ☉	★ / ☉	

(1) IP 65 with Ø 1 fibre / IP 64 with Ø 0.5 fibre.

Ecofibre system, assemble your own plastic fibres



Fibre Ø 1 mm	Length = 10 m	Length = 20 m
References	XUFZ910	XUFZ920

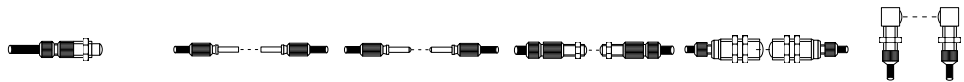

End fittings	70	200	800	1200	4000	1200
Sensing distance (mm)	70	200	800	1200	4000	1200
Type	with threaded end fitting	with plain end fitting, Ø 3, L = 9 mm	with plain end fitting, Ø 3, L = 9 mm	with threaded end fitting	with threaded end fitting	90° mirror, with threaded end fitting
Thread	M8 x 1, L = 10 mm	-	-	M6 x 1, L = 10 mm	M6 x 1, L = 10 mm	M6 x 1, L = 3 to 10 mm
Lens	yes	no	yes	yes	yes	yes
References	XUYA110	XUYA210	XUYA211	XUYA212	XUYA213	XUYA220

Accessories

For thru-beam system plastic fibre optics	For all system plastic fibre optics	Plug-in PUR pre-wired female connectors (1)
Lenses For increasing sensing distance (pair) XUFZ01 With 90° mirror (pair) XUFZ02	Fibre trimmer For trimming fibres to length (included with all fibre optics) XUFZ11	Cable length 5 m, without LED pre-wired, elbowed pre-wired, straight XZCP1041L5 XZCP0941L5
Fixing clamp with lens (set of 2) Front screw fixing for fibre optics XUFZ920 XUFZ04	Protective metal tubing Length 1 m, for fibres with threaded end fittings For M4 thread XUFZ210 For M6 thread XUFZ310	(1) For PVC cable see page 47

Plastic fibre optic light guides (length 2 m)



	M4 / M2.6 (1)	M4 / L = 90 mm	M3 / M2.6 (1)	Long range fibres with integrated lens M8 / L = 20 mm	Long range fibres M4 / M2.6 (1)	Flexible fibres M4 / M2.6 (1)
System	Thru-beam					
Sensing distance (mm)	200 or 1500 (2)	180	50 or 1000 (2)	2500	300 or 2000 (2)	100 or 750 (2)
Fibre cross-section						
Fibre Ø (mm)	Ø 1	Ø 1	Ø 0.5	Ø 1	Ø 1.5	Ø 1
Sheath Ø (mm)	Ø 2.2	Ø 2.2	Ø 1	Ø 2.2	Ø 2.2	Ø 2.2
Temperature range (°C)	- 25...+ 60	- 25...+ 60	- 25...+ 60	- 25...+ 60	- 25...+ 60	- 25...+ 60
References	XUFN12301	XUFN12311	XUFN35301	XUFN2L01L2	XUFN2P01L2	XUFN2S01L2
Fixing	M4 x 0.7	M4 x 0.7	M3 x 0.5	M8 x 1.25	M2.6 x 0.45 / M4 x 0.7	M2.6 x 0.45 / M4 x 0.7

(1) Can be used with 90° mirror XUFZ02 (see preceding page).

(2) With lens accessory XUFZ01 (see preceding page)



	M6	M4 / M6	M6/L = 90 mm	M4 / M2.6
System	Diffuse			
Sensing distance (mm)	70	60	60	15
Fibre cross-section				
Fibre Ø (mm)	Ø 1	Ø 1+16 Ø 0.265	Ø 1	Ø 0.5 + 4 Ø 0.23
Sheath Ø (mm)	Ø 2.2 x 2	Ø 2.2 x 2	Ø 2.2 x 2	Ø 1 x 2
Temperature range (°C)	- 25...+ 60	- 25...+ 60	- 25...+ 60	- 25...+ 60
References	XUFN05321	XUFN05323	XUFN05331	XUFN02323
Fixing	M6 x 0.75	M6 x 0.75 / M4 x 0.7	M6 x 0.75	M4 x 0.7

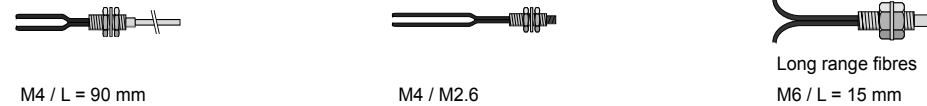

	M4 / L = 90 mm	M4 / M2.6	Long range fibres M6 / L = 15 mm
System	Diffuse		
Sensing distance (mm)	18	18	95
Fibre cross-section			
Fibre Ø (mm)	Ø 0.5	Ø 0.5	Ø 1.5
Sheath Ø (mm)	Ø 1 x 2	Ø 1 x 2	Ø 2.2 x 2
Temperature range (°C)	- 25...+ 60	- 25...+ 60	- 25...+ 60
References	XUFN01331	XUFN01321	XUFN5P01L2
Fixing	M4 x 0.7	M4 x 0.7	M6 x 0.75

Glass fibre optic light guides (length 0.6 m)

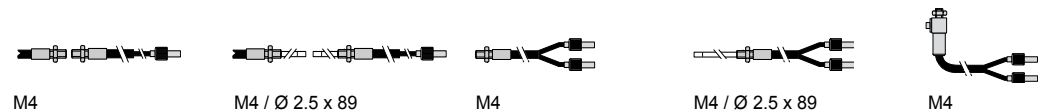

	M4	M4 / Ø 2.5 x 89	M4	M4 / Ø 2.5 x 89	M4
System	Thru-beam		Diffuse		
Sensing distance (mm)	200		80		
Fibre cross-section					
End fitting	Straight	Adaptable	Straight	Adaptable	90°
Fibre Ø (mm)	1		1		
Sheath Ø (mm)	2.2		2.2		
Temperature range (°C)	PVC sheath: - 25...+ 60 / Metal wound: - 25...+ 120 / Flexible stainless steel: - 25...+ 200				
References	PVC sheath	XUYFVERSD61	–	XUYFVPSD61	XUYFVPSC61
	Metal wound	XUYFVERMD61	XUYFVERSC61	XUYFVPM61	XUYFVPMC61
	Flexible stnl. steel	XUYFVERTD61	–	XUYFVPTD61	XUYFVPTC61
					XUYFVPSL61
					XUYFVPM61
					XUYFVPTL61



		M12	M18	M18
Nominal sensing distance Sn	Mode proximity or reflex (1)	5 or 10 cm depending on model	15 or 50 cm depending on model	50 mm
	Mode thru beam	20 cm	61 or 100 cm depending on model	
Operating zone for proximity mode		0.64...5.1 cm (XX512A1...) 0.64...10.2 cm (XX512A2...)	1.9...15.2 cm (XX518A1...) 5.1...50.8 cm (XX518A3...)	2...50 mm
Sensitivity adjustment		Fixed	Adjustable using remote control for XX518 A3. Fixed for XX518A1, XXT18, XXR18	Fixed
Case M (metal), P (plastic)		P	P	M
Product certification		CE	CE	CE
Temperature range (°C)		-20...+65	0...+50 (XX518A1...)/ -20...+65 (XX518A3...)/0...60 (XXT18, XXR18)	0...+60
Degree of protection (conforming to IEC 60529)		IP 67		
Dimensions (mm) Ø x L		M12 x 50	M18 x 65	M18 x 75 (M12) M18 x 65 (Cable)

Proximity or Reflex (1) mode with “Discrete” output for DC applications (24 V)

Connection			M8 connector	M12 connector	Pre-cabled (2 m), M12 connector
3-wire	PNP	NO function	XX512A2PAM8 (10 cm)	XX518A3PAM12 (50 cm)	XXV18B1PAL2 (cable) XXV18B1PAM12 (M12)
	NPN	NO function	XX512A2NAM8 (10 cm)	XX518A3NAM12 (50 cm)	XXV18B1NAL2 (cable) XXV18B1NAM12 (M12)
4-wire	PNP/NPN	NO function	XX512A1KAM8 (5 cm)	XX518A1KAM12 (15 cm)	–

Application - monitoring levels

	2 emptying levels	PNP NO function	–	XX218A3PHM12 (50 cm) (2)	–
	2 filling levels	PNP NO function	–	XX218A3PFM12 (50 cm) (2)	–
Supply voltage limits, min./max. (V) including ripple			10...28		
Switching capacity, max. (mA)			<100		
Short-circuit protection (★)			★		
LED output state indicator (⊗) / Power on LED (⊗)			⊗ / ⊗	⊗ / ⊗ except XX518A1.. (-/-)	
Voltage drop, closed state (V) at I nominal			<1		
Switching frequency (Hz)			125	40 / 80 (XX518A1..)	
Transmission frequency (kHz)			500	300	

(1) Reflex mode only for sensor with adjustable sensitivity.

(2) 1 NO

Proximity mode with “Analogue” output for DC applications (24 V)

Connection			M12 connector		
4-wire	Analogue	0...10 V output	–	XX918A3F1M12 (50 cm)	–
		4...20 mA output	–	XX918A3C2M12 (50 cm)	–
Supply voltage limits, min./max. (V) including ripple			–	10...28	–
Short-circuit protection (★)			–	★	–
LED output state indicator (⊗) / Power on LED (⊗)			–	⊗ / ⊗	–
Transmission frequency (kHz)			–	300	–

Thru beam mode with “Discrete” output for DC applications (24 V)

Connection		M8 connector	M12 connector	
4-wire	Receiver (NO/PNP + NO NPN)	XXR12A8KAM8	XXR18A3KAM12 (0.61 m) XXR18A4KAM12 (1 m)	–
	Receiver (NC/PNP + NC NPN)	XXR12A8KBM8	XXR18A3KBM12 (0.61 m) XXR18A4KBM12 (1 m)	–
	Transmitter	XXT12A8M8	XXT18A3M12 (0.61 m) XXT18A4M12 (1 m)	–

Accessories

See page 45 for programming and connectors, and page 46 for fixing

Ultrasonic sensors

Detection of any material



	M30			M30 Long range
Nominal sensing distance Sn Mode proximity or reflex (1)	1 m	1 m	2 m	8 m
Operating zone for proximity mode	0.1...1 m	0.05...0.99 m	0.12...2 m	0.3...8 m
Sensitivity adjustment	Adjustable using remote control	Adjustable using teach mode		
Case M (metal), P (plastic)	P			P
Product certification	CE			CE
Temperature range (°C)	0...+ 70	0...+ 70		- 20...+ 60
Degree of protection (conforming to IEC 60529)	IP 67	IP 65		
Dimensions (mm) Ø x L	M30 x 78	M30 x 85		M30 x 106

Proximity or Reflex (1) mode with “Discrete” output for DC applications (24 V)

Connection			M12 connector			M12 connector
3-wire	PNP	NO function	XX6V3A1PAM12	–	–	–
	NPN	NO function	XX6V3A1NAM12	–	–	–
4-wire	PNP/NPN	NO function	–	XX630A1KAM12	–	–
	PNP	NO + NC function	–	XX630A1PCM12 (2)	–	XX630A3PCM12
	NPN	NO + NC function	–	XX630A1NCM12 (2)	–	XX630A3NCM12

Application - monitoring levels

2 emptying levels	PNP NO function	–	XX230A10PA00M12 (3)	XX230A20PA00M12 (3)	–
2 filling levels	PNP NO function	–	XX230A11PA00M12 (3)	XX230A21PA00M12 (3)	–
Supply voltage limits, min./max. (V) including ripple		10...28			
Switching capacity, max. (mA)		<100			
Short-circuit protection (★)		★			
LED output state indicator (⊗) / Power on LED (⊗)		⊗ / ⊗			
Voltage drop, closed state (V) at I nominal		<1			
Switching frequency (Hz)		70	10		2
Transmission frequency (kHz)		180	200		75

(1) Reflex mode only for sensor with adjustable sensitivity.

Proximity mode with “Analogue” output for DC applications (24 V)

Connection			M12 connector			
4-wire	Analogue	0...10 V output	XX9V3A1F1M12	XX930A1A1M12 (2)	–	XX930A3A1M12
		4...20 mA output	XX9V3A1C2M12	XX930A1A2M12 (2)	–	XX930A3A2M12
Supply voltage limits, min./max. (V) including ripple		10...28	10...28	–	–	10...28
Short-circuit protection (★)		★	★	–	–	★
LED output state indicator (⊗) / Power on LED (⊗)		⊗ / ⊗	⊗ / ⊗	–	–	⊗ / ⊗
Transmission frequency (kHz)		180	200	–	–	75

(2) Stainless steel 303 version also available. To order, replace the first letter **A** in the reference by **S**. Example: XX630A1PCM12 becomes XX630S1PCM12.

(3) 2 NO

Accessories

Programming

Remote control

teach button for use with sensors XX●18A3●●●, XX●V1●●●, XX●V3●●● and XX●D1

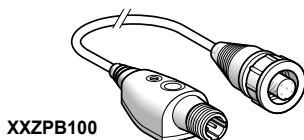

Suitable female plug-in connectors

PUR Pre-wired connectors (1)

elbowed



straight

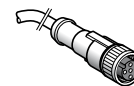

Other connectors

screw terminal



L = 5 m (without LED)

M8	for XX512A1...	XZCP1041L5	XZCP0941L5	XZCC8FCM40V
	for XX512A2...	XZCP0666L5	XZCP0566L5	XZCC8FCM30V
M12	for all sensors except XX512...	XZCP1241L5	XZCP1141L5	XZCC12FCM40B

(1) For PVC cable see page 47

For fixing see page 46



	Mini flat	Flat	Combined multi-fixing	Flat 80 x 80
Nominal sensing distance Sn	10 cm	25 cm	50 cm	1 m
Mode proximity or reflex (1)				
Mode thru beam	20 cm	61 or 100 cm depending on model	–	–
Operating zone for proximity mode	0.62...10.2 cm	5.1...25.4 cm	5.1...50.8 cm	0.1...1 m
Sensitivity adjustment	Fixed	Fixed	Adjustable using remote control	Adjustable using remote control
Case P (plastic)	P	P	P	P
Product certification	CE	CE	CE	CE
Temperature range (°C)	-20...+65	0...+50	-20...+65	0...+70
Degree of protection (conforming to IEC 60529)	IP 67			
Dimensions (mm) Ø x L or H x W x D	33 x 19 x 7.6	74 x 30 x 16	M 18 / 18 x 33 x 60	80 x 80 x 34

Proximity or Reflex (1) mode with “Discrete” output for DC applications (24 V)

Connection			M12 on 0.15 m flying lead	M12 connector		
3-wire	PNP	NO function	XX7F1A2PAL01M12	XX7K1A2PAM12	XX7V1A1PAM12	XX8D1A1PAM12
	NPN	NO function	XX7F1A2NAL01M12	XX7K1A2NAM12	XX7V1A1NAM12	XX8D1A1NAM12
Supply voltage limits, min./max. (V) including ripple			10...28			
Switching capacity, max. (mA)			<100			
Short-circuit protection (★)			★			
LED output state indicator (⊗) / Power on LED (⊗)			⊗ / ⊗			
Voltage drop, closed state (V) at I nominal			<1			
Switching frequency (Hz)			100	80	40	70
Transmission frequency (kHz)			500	500	300	180

(1) Reflex mode only for sensor with adjustable sensitivity.

Proximity mode with “Analogue” output for DC applications (24 V)

Connection			–	–	M12 connector	–
4-wire	Analogue	0...10 V output	–	–	XX9V1A1F1M12	XX9D1A1F1M12
		4...20 mA output	–	–	XX9V1A1C2M12	XX9D1A1C2M12
Supply voltage limits, min./max. (V) including ripple			–			
Short-circuit protection (★)			–			
LED output state indicator (⊗) / Power on LED (⊗)			–			
Transmission frequency (kHz)			–	–	300	180

Thru beam mode with “Discrete” output for DC applications (24 V)

Connection		–	–	–	–
4-wire	Receiver (NO/PNP + NO/NPN)	XXRF1A8KAM12L	XXRK1A3KAM12 (0,61m) XXRK1A4KAM12 (1m)	–	–
	Receiver (NC/PNP + NC/NPN)	XXRF1A8KBM12L	XXRK1A3KBM12 (0,61m) XXRK1A4KBM12 (1m)	–	–
	Transmitter	XXTF1A8M12L	XXTK1A3M12 (0,61m) XXTK1A4M12 (1m)	–	–

Accessories

Fixings - 3D fixings with ball joint

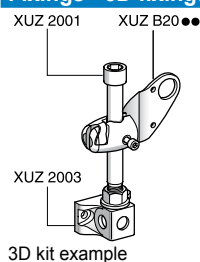

Bracket with ball joint for cylindrical sensors

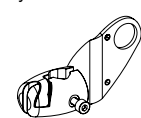

for	
Ø 12	XUZB2012
Ø 18	XUZB2003
Ø 30	XUZB2030

M12 rod for ball joint



XUZ2001

Fixing support for M12 rod

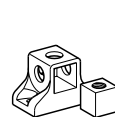

XUZ2003

Simple fixings

90° fixing brackets

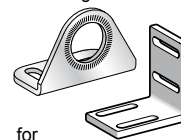

for	
Ø 12	XXZ12
Ø 18	XUZA118
Ø 30	XXZ30
XX7F	XXZ1933

Mounting plates for XX7K

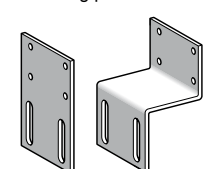

flat	XXZ3074F
cranked	XXZ3074S

See page 45 for programming and connectors

PVC cable
M8 and M12 connector

PVC cable
1/2" and 7/8" connector

PUR cable halogen free
M8, M12, 1/2" and 7/8" connector

Reinforced PVC cable, stainless steel ring
M8, M12, 1/2" and 7/8" connector

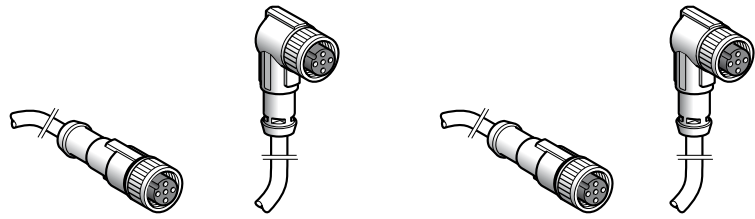

Connector Size		M8	M8	M8	M8
		Straight 3 pin	Elbowed 3 pin	Straight 4 pin	Elbowed 4 pin
References	PVC cable	XZCPV0566L●	XZCPV0666L●	XZCPV0941L●	XZCPV1041L●
	PUR cable	XZCP0566L●	XZCP0666L●	XZCP0941L●	XZCP1041L●
	PVC cable IP69K	XZCPA0566L●	-	XZCPA0941L●	-

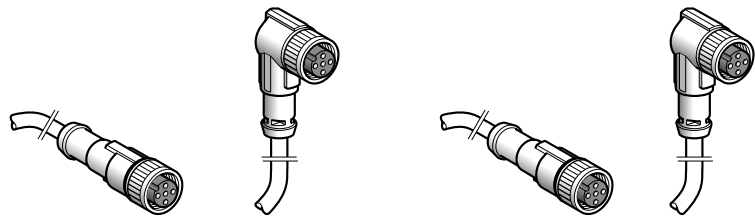

Connector Size		M12	M12	M12	M12
		Straight 4 pin	Elbowed 4 pin	Straight 5 pin	Elbowed 5 pin
References	PVC cable	XZCPV1141L●	XZCPV1241L●	XZCPV1164L●	XZCPV1264L●
	PUR cable	XZCP1141L●	XZCP1241L●	XZCP1164L●	XZCP1264L●
	PVC cable IP69K	XZCPA1141L●	XZCPA1241L●	XZCPA1164L●	-

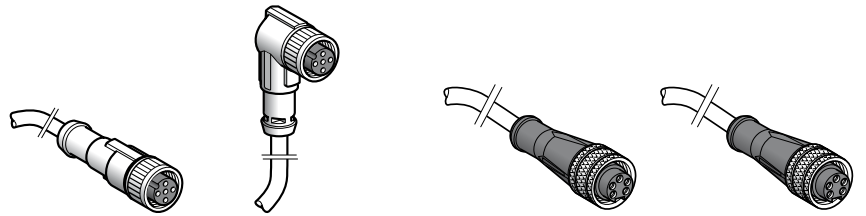

Connector Size		1/2"	1/2"	7/8"	7/8"
		Straight 3 pin	Elbowed 3 pin	Straight 3 pin	Straight 5 pin
References	PVC cable	XZCPV1865L●	XZCPV1965L●	XZCPV1670L●	-
	PUR cable	XZCP1865L●	XZCP1965L●	XZCP1670L●	XZCP1764L●
	PVC cable IP69K	XZCPA1865L●	XZCPA1965L●	-	-

Complete each reference by adding the length of cable, as 2 for 2 m, 5 for 5 m and 10 for 10 m
Eg: XZCPV1141L2 is pre-wired connector M12 connectors with 4 contacts and 2 m PVC cable

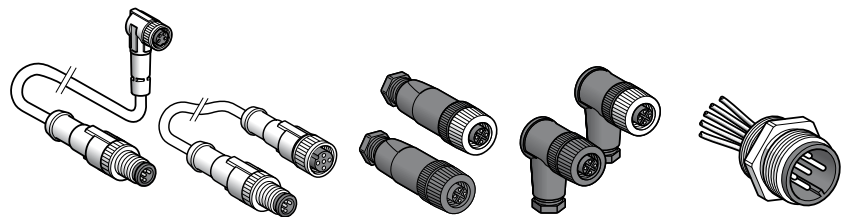

Other accessories	Jumpers	Connector	Receptacle
References	XZCR...	XZCC...	XZCE...



Diameter of housing (mm)	Ø 40	Ø 40	Ø 58	Ø 58	Stainless steel 316L	Ø 58 Parametrable	Ø 90
Shaft Ø (mm)	Ø 6	Ø 6	Ø 6	Ø 10		Ø 14 (1)	Ø 12
Type of shaft (2)	solid shaft	through shaft	solid shaft	solid shaft		through shaft	solid shaft
Maximum rotational speed (rpm)	9000	9000	9000	9000		6000	6000
Maximum frequency (kHz)	100	100	300	300		300	100
Maximum load (daN)	2	2	10	10	25	5	20
Torque (N.cm)	0.2	0.25	0.4	0.4		0.6	1
Product certification	CE	CE	CE	CE		CE	CE
Temperature range (°C)	- 20...+ 80	- 20...+ 80	- 30...+ 100	- 30...+ 100		- 30...+ 70	- 20...+ 80
Degree of protection (conforming to IEC 60529)	IP 54	IP 52	IP 65 / IP 67 (3)	IP 65 / IP 67 (3)	IP69K	IP 65	IP 66
Supply voltage	5 V, RS 422	4.5...5.5 V	4.75...30 V	4.75...30 V		4.75...30 V	4.5...5.5 V
Push-pull		11...30 V	11...30 V	5...30 V	5...30 V	5...30 V	11...30 V
Connection	Pre-cabled (2 m), radial		M23 male connector, radial		Pre-cabled (2 m), axial	M23 male connector, radial	
Resolution (Points)	Output stage						
100	5 V, RS 422	XCC1406PR01R	XCC1406TR01R	XCC1506PS01X	XCC1510PS01X	-	XCC1912PS01RN
Push-pull		XCC1406PR01K	XCC1406TR01K	XCC1506PS01Y	XCC1510PS01Y	-	XCC1912PS01KN
360	5 V, RS 422	XCC1406PR03R	XCC1406TR03R	XCC1506PS03X	XCC1510PS03X	-	XCC1912PS03RN
Push-pull		XCC1406PR03K	XCC1406TR03K	XCC1506PS03Y	XCC1510PS03Y	XCC1510SPA03Y	XCC1912PS03KN
500	5 V, RS 422	XCC1406PR05R	XCC1406TR05R	XCC1506PS05X	XCC1510PS05X	-	XCC1912PS05RN
Push-pull		XCC1406PR05K	XCC1406TR05K	XCC1506PS05Y	XCC1510PS05Y	-	XCC1912PS05KN
1000	5 V, RS 422	XCC1406PR10R	XCC1406TR10R	XCC1506PS10X	XCC1510PS10X	-	XCC1912PS10RN
Push-pull		XCC1406PR10K	XCC1406TR10K	XCC1506PS10Y	XCC1510PS10Y	-	XCC1912PS10KN
1024	5 V, RS 422	XCC1406PR11R	XCC1406TR11R	XCC1506PS11X	XCC1510PS11X	-	XCC1912PS11RN
Push-pull		XCC1406PR11K	XCC1406TR11K	XCC1506PS11Y	XCC1510PS11Y	XCC1501SPA11Y	XCC1912PS11KN
2500	5 V, RS 422	-	-	XCC1506PS25X	XCC1510PS25X	-	XCC1912PS25RN
Push-pull		-	-	XCC1506PS25Y	XCC1510PS25Y	-	XCC1912PS25KN
3600	5 V, RS 422	-	-	-	-	-	XCC1912PS36RN
Push-pull		-	-	-	-	-	XCC1912PS36KN
256...4096	5 V, RS 422	-	-	-	-	XCC1514TSM02X	-
Push-pull		-	-	-	-	XCC1514TSM02Y	-
5000	5 V, RS 422	-	-	XCC1506PS50X	XCC1510PS50X	-	XCC1912PS50RN
Push-pull		-	-	XCC1506PS50Y	XCC1510PS50Y	XCC1510SPA50Y	XCC1912PS50KN
360...5760	5 V, RS 422	-	-	-	-	XCC1514TSM03X	-
Push-pull		-	-	-	-	XCC1514TSM03Y	-
500...8000	5 V, RS 422	-	-	-	-	XCC1514TSM05X	-
Push-pull		-	-	-	-	XCC1514TSM05Y	-
10 000	5 V, RS 422	-	-	-	-	-	XCC1912PS00RN
Push-pull		-	-	-	-	-	XCC1912PS00KN
1024...16 384	5 V, RS 422	-	-	-	-	XCC1514TSM11X	-
Push-pull		-	-	-	-	XCC1514TSM11Y	-
5000...80 000	5 V, RS 422	-	-	-	-	XCC1514TSM50X	-
Push-pull		-	-	-	-	XCC1514TSM50Y	-

Accessories

Shaft couplings

with spring	Bore diameter (encoder side)	Bore diameter (machine side)	Reference
	6 mm	6 mm	XCCRAR0606
	6 mm	8 mm	XCCRAR0608
	6 mm	10 mm	XCCRAR0610
	10 mm	10 mm	XCCRAR1010
	10 mm	12 mm	XCCRAR1012
elastic	6 mm	6 mm	XCCRAE0606

Fixing brackets

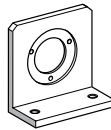
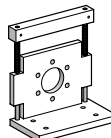
Plain bracket	for Ø 58 mm	XCCRE5SN
	for Ø 90 mm	XCCRE9SN
	Bracket with play compensator	
	for Ø 58 mm	XCCRE5RN
	for Ø 90 mm	XCCRE9RN

Absolute - single turn

Absolute - multiturn

Communicating multiturn absolute

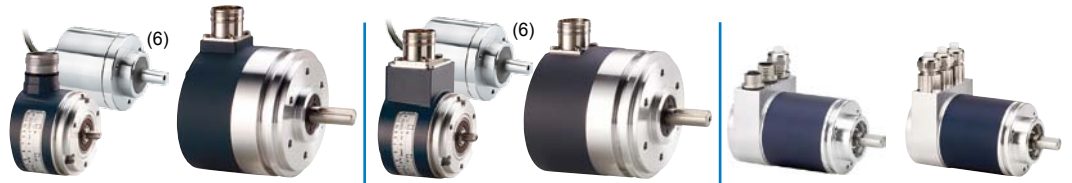

Diameter of housing (mm)	Ø 58	Ø 90	Ø 58	Ø 90	Ø 58 CANopen	Ø 58 PROFIBUS-DP
Shaft Ø (mm)	Ø 10	Ø 12	Ø 10	Ø 12	Ø 10	Ø 10
Type of shaft (2)	solid shaft	solid shaft	solid shaft	solid shaft	solid shaft (4)	solid shaft (4)
Maximum rotational speed (rpm)	9000	6000	6000	6000	6000	6000
Maximum frequency (kHz)	100	100 (1000 SSI)	100 (500 SSI)	100 (500 SSI)	800	800
Maximum load (daN)	10 / 25 (6)	20	10	20	11	11
Torque (N.cm)	0.4	1	0.4	1	0.3	0.3
Product certification	CE	CE	CE	CE	CE	CE
Temperature range (°C)	- 20...+ 90	- 20...+ 85	- 20...+ 85	- 20...+ 85	- 40...+ 85	- 40...+ 85
Degree of protection (conforming to IEC 60529)	IP 65 / IP 67 (3) / IP69K (6)	IP 66	IP 65 / IP 67 (3) / IP69K (6)	IP 66	IP 64	IP 64
Supply voltage	11...30 V					
Connection	M23 male connector, radial / 2m Axial cable (6)				2 x M12 + 1 x Pg 9	3 x Pg 9
Resolution	Output stage	Code				
... 8192 points	Push-pull	Binaire	XCC2510PS81KB	XCC2912PS81KBN	-	-
		Gray	XCC2510PS81KGN XCC2510SPA81KGN (6)	XCC2912PS81KGN	-	-
	SSI, 13 bits	Binaire	XCC2510PS81SBN	XCC2912PS81SBN	-	-
		Gray	XCC2510PS81SGN XCC2510SPA81SGN (6)	XCC2912PS81SGN	-	-
4096 points / 8192 turns	SSI, 25 bits (5)	Gray	-	-	XCC3510PS48SGN XCC3510SPA48SGN (6)	-
8192 points / 4096 turns	SSI, 25 bits (5)	Binaire	-	-	XCC3510PS84SBN	XCC3912PS84SBN
		Gray	-	-	XCC3510PS84SGN	XCC3912PS84SGN
8192 points / 4096 turns	CANopen, 25 bits	Binaire	-	-	-	-
			-	-	-	XCC3510PS84CBN
	PROFIBUS-DP, 25 bits	Binaire	-	-	-	-
			-	-	-	XCC3510PV84FBN

(1) Anti-rotation device included with through shaft version encoders. To achieve Ø 6, 8, 10 or 12 mm through shafts, use the reduction collars.

(2) All versions are also available with through shaft and anti-rotation device.

(3) IP 67 with sealed collar XCCRB3.

(4) Versions available with hollow shaft and anti-rotation device.

(5) "Parallel" outputs possible for multiturn absolute encoders using deserialisation jumper cables XCCRM23SUB37●●.

(6) product in Stainless steel 316L

Reduction collars

For Ø 58 mm incremental encoders with through shaft

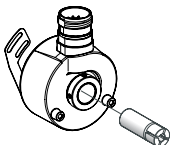

Ø 14 to Ø 6 mm	XCCR158RDA06
Ø 14 to Ø 8 mm	XCCR158RDA08
Ø 14 to Ø 10 mm	XCCR158RDA10
Ø 14 to Ø 12 mm	XCCR158RDA12

IP 67 sealed collar

For encoders XCC1510, 2510, 3510

Ø 58 mm	XCCRB3
---------	--------

Pre-wired connectors and jumper cables

Pre-wired M23 female connectors (cable length 5 m)



8-wire for SSI encoders	XCCPM23122L5
10-wire for incremental encoders	XCCPM23121L5
16-wire for parallel single turn absolute encoders	XCCPM23161L5

Deserialisation jumper cables (M23 F - SUB-D37 M) (L = 0.5 m)



SSI Gray - // Gray PNP	XCCRM23SUB37PG
SSI binary - // binary NPN	XCCRM23SUB37PB



Presentation

OsiSense XG is open to the majority of ISO 18000-3, ISO 15693 and ISO 14443 electronic tags.

OsiSense XG integrates Modbus RTU, Uni-Telway, Modbus TCP/IP (using Ethernet box XGCS333ETH) and Profibus DP (with box XGCS333PDP) protocols.

The OsiSense XG RFID offer comprises:

- 3 models of 13.56 MHz smart antenna (read/write)
- 12 models of 13.56 MHz electronic tags
- 1 portable RFID diagnostics terminal
- 3 models of network connection boxes plus connection and mounting accessories.

Setting-up

OsiSense XG smart antenna are simple to set-up:

- Integrated RFID and network functions
- No programming
- Automatic detection of the RFID electronic tags (read or write)
- Automatic setting of the communication parameters (speed, format, parity, protocol, etc.)
- Configuration of the network address (1 to 15) using badge included with the smart antenna
- Low sensitivity to metal environments.

Installation

OsiSense XG smart antenna easily integrate in flexible manufacturing production lines:

- quick connection using M12 connector
- screw fixing or clip-on mounting.



Smart antenna, 13.56 MHz		Flat form 40	Flat form 80
Dimensions (mm), W x H x D		40 x 40 x 15	80 x 80 x 26
Nominal sensing distance depending on tag (mm)		18 to 70	20 to 100
Type of associated tag		ISO 15693 and ISO 14443 standard tags. Automatic detection of the type of tag.	
Display		dual colour LED for the communication network, dual colour LED for the RFID communication	
Conformity to standards		CE, EN 301489-1, EN 301489-3, ETS 300330-1 and ETS 300330-2, FCC part 15 - UL	
Degree of protection conforming to IEC 60529		IP 67	
Serial link	Type	RS 485	Ethernet (dual port)
	Protocol	Modbus and Uni-Telway	MODBUS TCP/IP and EtherNet/IP
	Speed (Bauds)	9600...115 200 (automatic detection)	10/100MB
Ambient air temperature (°C)		For operation: - 25...+ 70 °C, for storage: - 40...+ 85 °C	
Nominal supply voltage		24 VDC PELV (Protective Extra Low Voltage)	
Connection		M12, 5-pin male, shielded connector on flying lead. Only for connection to the communication network and the supply	M12 (Ethernet) - M8 4pin (Power supply)
References		XGCS4901201	XGCS8901201 XGCS850C201



Electronic tags		Flat form 40		ISO badge (1)	Disc	Flat form 26	Cylindrical
Dimensions (mm), W x H x D		40 x 40 x 15		54 x 85.5 x 0.8	Ø 30 x 3	26 x 26 x 13	M18 x 1 x 12
Type of memory		EEPROM	FRAM	EEPROM			
Memory capacity (bytes)		3 408	32 768	256	112	256	256
Nominal sensing distance (mm) (Read/Write)	With station XGCS49●	33	25	70	48	40	18
	With station XGCS89●	48	39	100	65	55	20
Time (ms)	Read	9.25 + 0.375 x n (2)	6 + 0.25 x n (2)	12 + 0.825 x n (2)			
	Write	13 + 0.8 x n (2)	6 + 0.25 x n (2)	20 + 11.8 x n (2)	12 + 5.6 x n (2)	20 + 11.8 x n (2)	19 + 4.1 x n (2)
Degree of protection conforming to IEC 60529		IP 68		IP 65		IP 68	
Standard supported		ISO 14443		ISO 15693			
Mounting on metal support		Yes		No		Yes	No
References		XGHB444345	XGHB443245	XGHB90E340	XGHB320345	XGHB221346	XGHB211345

(1) Customised versions on request. (2) n = number of 16-bit words.



Connection boxes	Ethernet Modbus TCP/IP box	Profibus box	EtherNet/IP box
Dimensions (mm), W x H x D	130 x 80 x 51		130 x 80 x 51
Protocols	Modbus TCP/IP	Profibus DP	EtherNet/IP
Supply voltage	24 VDC PELV. M12, 4-pin male, A coding, connector		
Conformity to standards	CE - UL	CE	CE
Station connection	M12, 5-pin female, A coding, connector		
Degree of protection conforming to IEC 60529	IP 65		
References	XGSZ33ETH	XGSZ33PDP	XGSZ33EIP



Terminal	Portable 13.56 MHz RFID diagnostics terminal
Dimensions (mm), W x H x P	78 x 153 x 27
Function	Read/Write operations on electronic tags
Operating system	Proprietary OS
Conformity to standards	CE, FCC class A, Part 15
Display	53 x 95 mm colour OLED touchscreen 272 x 480 pixels resolution
Degree of protection conforming to IEC 60529	IP 40
Memory	RAM: 256 Mb Storage: internal 2 GB + USB socket for memory stick
Reference	XGST2422 (battery, battery charger, 2 GB USB memory stick, and carrying case included with terminal). RFID reader to be ordered separately: XGCS4901201 (integrated reader) or XGW4F111 (remote reader)



Description	for Modbus network		for Profibus	for Ethernet	Pre-wired connector	"T" connector	
	Modbus connecting cable M12 connectors Male / Female	Pre-wired connector M12 male / Bare wires	Modbus connecting cable M12 female / Mini-DIN 8	Profibus connecting cables M12 connectors Male / Female	Ethernet connecting cable M12 male / RJ 45	Pre-wired supply connector M12 female	Network M12 "T" connector 1 male / 2 female
Application	RS485 connection between a smart antenna and a connection box or between 2 Modbus boxes	Connection between a Modbus box and a Modbus / Uni-Telway network	Connection between a Modbus box and a PLC	Connection between Profibus box and Profibus network	Connection between an Ethernet box and the Ethernet network	24 VDC supply to connection boxes	For chaining of smart antennas on RS485 network
L = 2 m	TCSMCN1M1F2	TCSMCN1F2	TCSMCN1F9M2P	FTXDP1220	XGSZ12E4503 (3)	XGSZ09L2	TCSCN011M11F
L = 5 m	TCSMCN1M1F5	TCSMCN1F5	-	FTXDP1250	XGSZ12E4510 (4)	XGSZ09L5	

(3) L = 3 m (4) L = 10 m

Field expander	RS232/RS485 converter	Technical documentation
To be associated with a smart antenna XGCS4901201 for conveying and handling applications	For connecting a PC to an OsiSense XG smart antenna	OsiSense XG smart antenna guide
 50 x 400 mm XGFEC540	 XGSZ24	 DIA4ED3051001

Preventa, the safety attitude around your machine life cycle

The Preventa range enhances safety throughout a machine's entire life cycle from design, manufacture, installation, adjustment, operation and servicing right through to decommissioning.

In addition to moral obligation and economic consequences, the law requires that machinery is safe in the interests of accident prevention. Preventa offers an extensive range of safety products, compliant with international standards, designed to provide the most comprehensive protection for personnel and equipment.

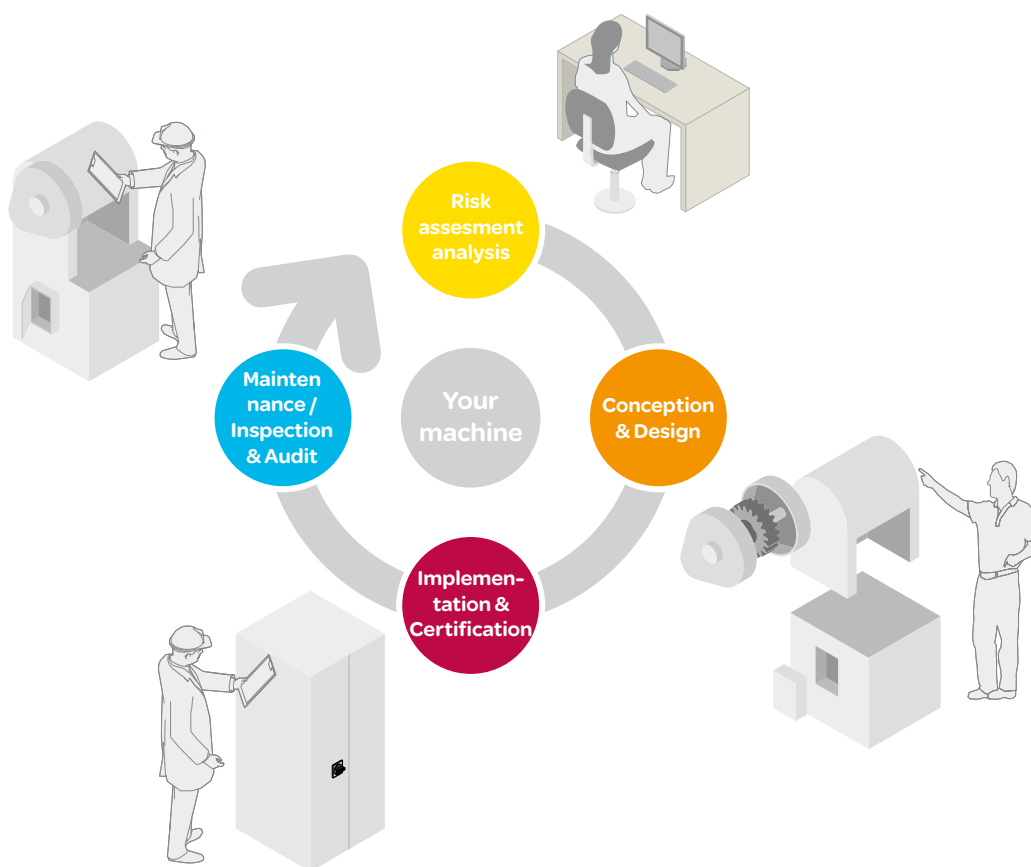

● New machines - the Machinery Directive

The previous Machinery Directive 98/37/EC was elaborated to help manufacturers ensuring a minimum safety level for machinery and equipment sold within the EU (European Union).

From 29 December 2009 on, the new European Machinery Directive 2006/42/EC is effective. Machines must comply with the Essential Health and Safety Requirements (EHSRs) listed in Annex I of the Directive, thus setting a common minimum level of protection across the EEA (European Economic Area).

Machine manufacturers, or their authorised representatives within the EU, must ensure that the machine is compliant with all requirements from this Directive. This technical file is available to reinforce authorities requests as well as the CE marking must be affixed and a Declaration of Conformity has been signed before the machine may be placed on the market within the EU.

Functional safety

- Safety integrity level (SIL), Performance level (PL)

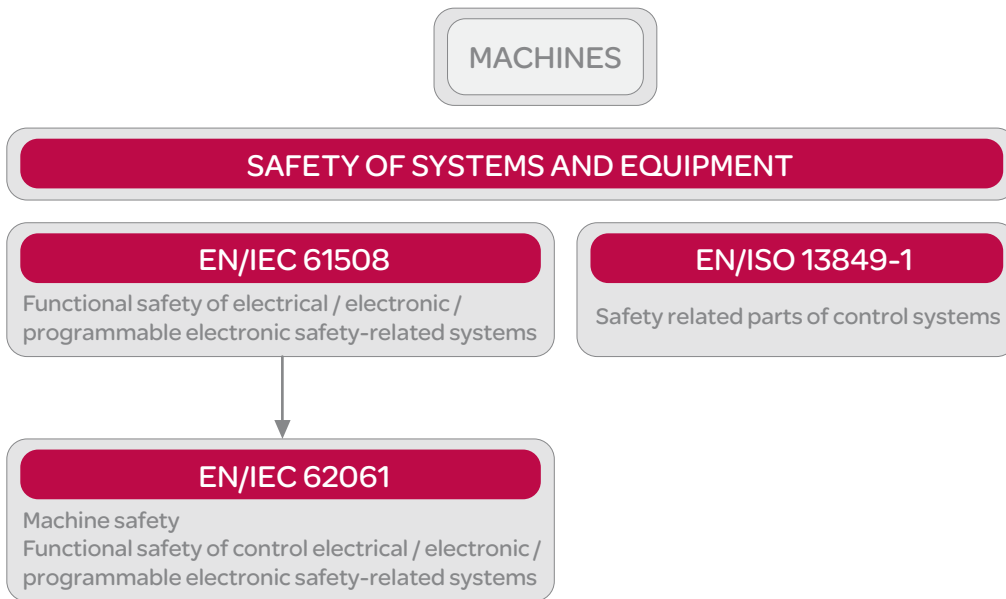

Risk reduction according to EN/IEC 61508 and EN/ISO 13849-1

- **Safety** is achieved by risk reduction (for those hazards that cannot be designed-out).
- **Residual risk** is the risk remaining after protective measures have been taken.
- **Protective measures** realised by E/E/PE* safety related systems contribute to risk reduction.

* Electric / Electronic / Programmable electronic

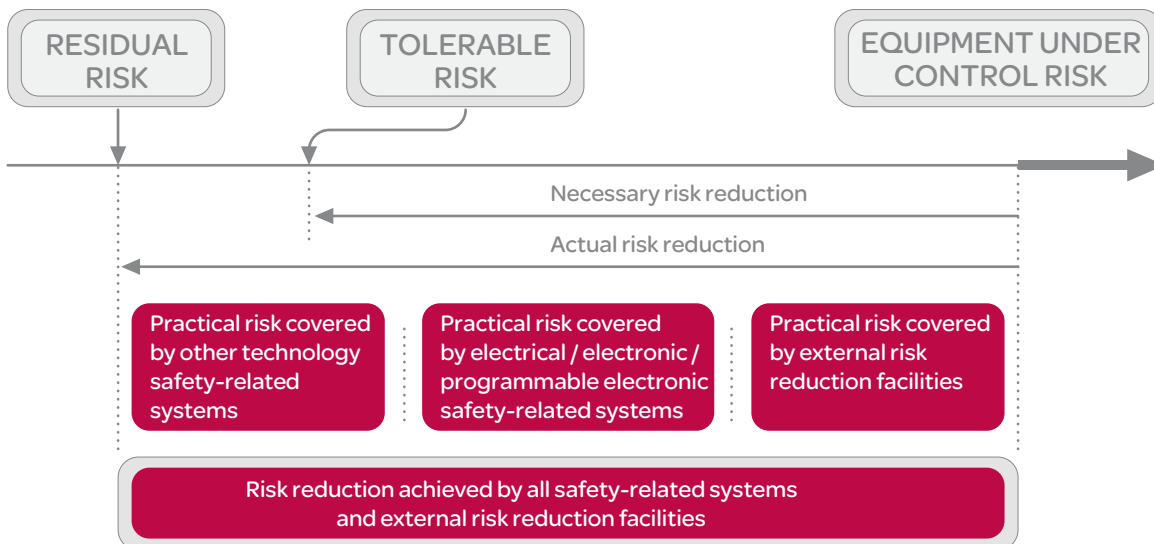

Functional safety of machinery

● Approach according to EN/IEC 62061

Risk estimation for SIL assignment

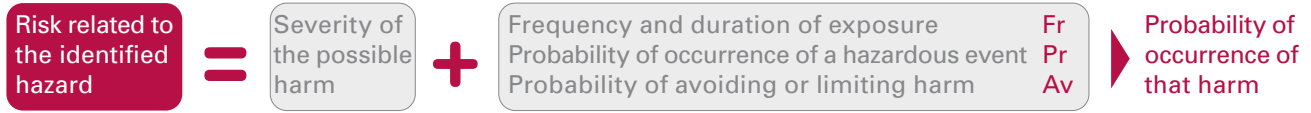

Example of SIL assignment

This assignment should be carried by determining the risk parameters that are shown below in an example.

Consequences		Severity (Se)	
Irreversible: death, losing an eye or arm		4	
Irreversible: broken limb(s), losing a finger(s)		3	
Reversible: requiring attention from a medical practitioner		2	
Reversible: requiring first aid		1	

Frequency and duration of exposure (Fr)		Probability of occurrence		Probability (Pr)		Probability of avoiding or limiting harm (Av)	
Frequency of exposure	> 10 min	Very high			5	Impossible	5
1 h	5	Likely	4	Possible	3	Rarely	3
> 1 h to 1 day	5	Possible	3	Rarely	2	Probable	1
> 1 day to 2 weeks	4	Rarely	2	Negligible	1		
> 2 weeks to 1 year	3						
> 1 year	2						

Serial no.	Hazard	Se	Fr	Pr	Av	CI
1	Hazard X	4	5	4	3	12
2						

Consequences	(Se)	Class CI					Frequency and duration		Probability of hzd. Event		Avoidance	
		3-4	5-7	8-10	11-13	14-15	Fr	Pr	Pr	Av	Av	
Death, losing an eye or arm	4	SIL 2	SIL 2	SIL 2	SIL 3	SIL 3	<= 1 hour	5	Common	5		
Permanent, losing fingers	3		OM	SIL 1	SIL 2	SIL 3	> 1 h to <= 1 day	5	Likely	4		
Reversible, medical attention	2			OM	SIL 1	SIL 2	> 1 day to <= 2 wks	4	Possible	3	Impossible	5
Reversible, first aid	1				OM	SIL 1	2 wks to <= 1 year	3	Rarely	2	Possible	3
							> 1 year	2	Negligible	1	Likely	1

In this example the SIL 3 must be achieved by the safety-related control function intended to reduce the risk related to the identified hazard.

Determination of the SIL level achieved by the Safety-related control function (SRCF)

According to standard EN/IEC 62061 for each safety related control function, the SIL level is linked to:

- a target failure value for the probability of dangerous failure by hour of the SRCF: PFHD
- architectural constraints (hardware fault tolerance, diagnosis)
- a set of requirements related to the lifecycle of the safety related electrical control system

Safety integrity level (SIL)	Probability of a dangerous Failure per Hour PFHD
3	>10 ⁻⁸ to <10 ⁻⁷
2	>10 ⁻⁷ to <10 ⁻⁶
1	>10 ⁻⁶ to <10 ⁻⁵

λ_s = rate of safe failures,
 λ_{dd} = rate of detected dangerous failures,
 λ_{du} = rate of undetected dangerous failures
 $\lambda_d = \lambda_{dd} + \lambda_{du}$

In practice, detected dangerous failure are dealt with by fault

- The rate of failures λ can be expressed as follows: $\lambda = \lambda_s + \lambda_{dd} + \lambda_{du}$
- The calculation of the PFHD for a system or subsystem depends on several parameters:
 - the dangerous failure rate (λ_d) of the subsystem elements
 - the fault tolerance (e.g. redundancy) of the system
 - the diagnostic test interval (T2)
 - the proof test interval (T1) or lifetime whichever is smaller
 - the susceptibility to common cause failures (β)
- For each of the four different logical architectures A to D there is a different formula to calculate the PFHD. (see EN/IEC 62061)
- For a simple system without redundancy and without diagnostic: $PFHD = \lambda_d \times 1/h$

● Approach according to EN/ISO 13849-1

Determination of the Performance Level requested (PLr)

Done using the risk graphic opposite

S = Severity of injury

S1 = Slight (normally reversible injury)

S2 = Serious (normally irreversible) injury including death

F = Frequency and/or exposure time to the hazard

F1 = Seldom to less often and/or the exposure time is short

F2 = Frequent to continuous and/or the exposure time is long

P = Possibility of avoiding the hazard or limiting the harm

P1 = Possible under specific conditions

P2 = Scarcely possible

L = Low contribution to risk reduction

H = High contribution to risk reduction

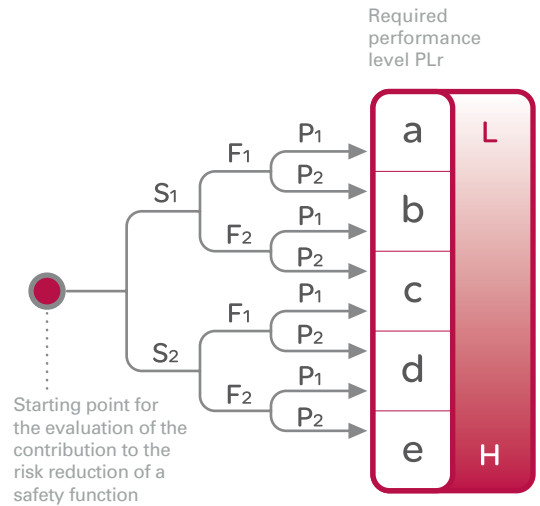

Determination of the PL achieved by the Safety-related parts of control systems (SRP/CS)

According to standard EN/ISO 13849-1, the Performance level (PL) is linked to a target failure value of probability of dangerous failure per hour for each safety related control function.

Performance level (PL)	Probability of a dangerous Failure per Hour
a	$\geq 10^{-5} \dots < 10^{-4}$
b	$\geq 3 \times 10^{-6} \dots < 10^{-5}$
c	$\geq 10^{-6} \dots < 3 \times 10^{-6}$
d	$\geq 10^{-7} \dots < 10^{-6}$
e	$\geq 10^{-8} \dots < 10^{-7}$

For a SRP/CS (or a combination of SRP/CS) designed according to the requirements of the article 6, the PL could be estimated with the figure beside after estimation of several factors such as system structure (categories), mechanism of failures detection [Diagnosis Coverage (DC)], components reliability [mean time to dangerous failure (MTTFd), Common Cause Failure (CCF)]...

- MTTF_d of each channel = low
- MTTF_d of each channel = medium
- MTTF_d of each channel = high

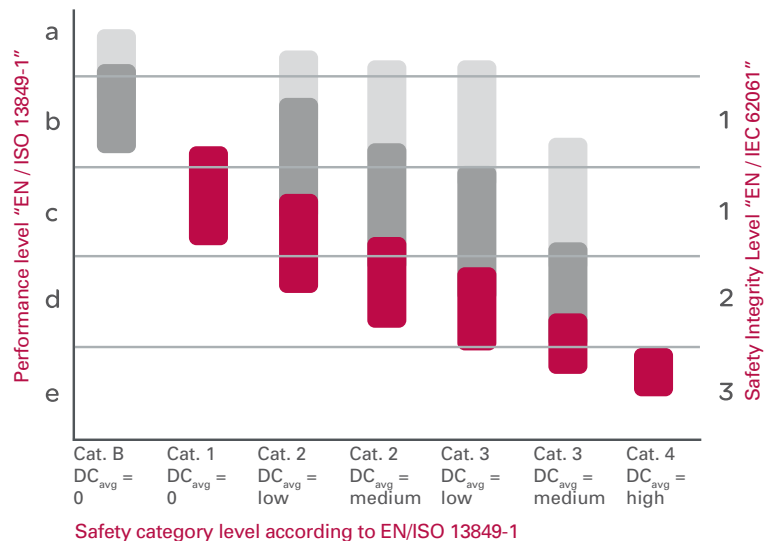
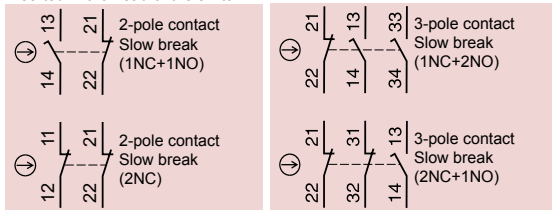
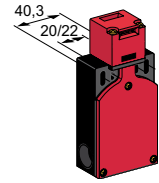
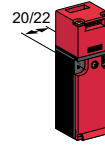
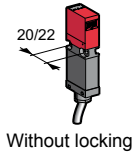

Illustration of contacts with the actuator inserted in the head of the switch



ISO entry
(to EN 50262)



Plastic, double insulated switches	Type XCSMP	Type XCSPA	Type XCSTA
Maximum safety level (3)	PL=e, category 4 conforming to EN/ISO 13849-1 and SIL CL3 conforming to EN/IEC 62061		
Actuation speed (min --> max)	0,05m/s --> 1,5m/s	0,1m/s --> 0,5m/s	0,1m/s --> 0,5m/s
Rated operational characteristics (conforming to EN IEC 60947-5-1)	AC 15, C 300 / DC 13, Q 300		
Degree of protection conforming to IEC 60529	IP67		
Reliability data B_{10d}	5 000 000 value given for a service life of 20 years, limited by mechanical or contact wear		
Body + Head dimensions (mm) W x D x H	30 x 15 x 87 mm	30 x 30 x 93,5 mm	52 x 30 x 114,5 mm
Resistance to forcible withdrawal of actuator	8 N	10 N (1)	10 N (1)
Wiring connection	pre-cabled, L = 2m	1 x ISO M16 entry.	1 x PG11 entry 2 x ISO M16 entries. (2)
Safety contacts	1NC+1NO break before make, slow break 2NC slow break 1NC+2NO break before make, slow break 2NC+1NO break before make, slow break 2NC+1NO snap action 3NC slow break	XCSMP59L2 ⊕ XCSMP79L2 ⊕ - XCSMP70L2 ⊕ - XCSMP80L2 ⊕	XCSPA592 ⊕ XCSPA792 ⊕ XCSPA892 ⊕ XCSPA992 ⊕ XCSPA492 ⊕ -
		XCSPA591 ⊕ XCSPA791 ⊕ XCSPA891 ⊕ XCSPA991 ⊕ XCSPA491 ⊕ -	- - XCSTA592 ⊕ XCSTA792 ⊕ - XCSTA892 ⊕

- (1) In order to increase the resistance to 50 N, you must add the accessory XCSZ21 to the key actuators XCSZ12
 (2) With entry for n° 11 (Pg 11) cable gland, replace the last digit in the reference by 1 (example: XCSTA592 becomes XCSTA591).

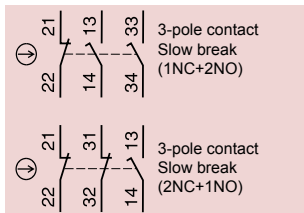

ISO entry
(to EN 50262)

Illustration of contacts with the actuator inserted in the head of the switch

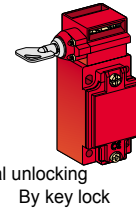
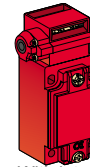
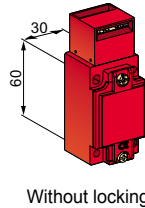

Metal, double insulated switches	Type XCSA	Type XCSB	Type XCSC
Maximum safety level (3)	PL=e, category 4 conforming to EN/ISO 13849-1 and SIL CL3 conforming to EN/IEC 62061		
Actuation speed (min --> max)	0,01m/s --> 0,5m/s	0,01m/s --> 0,5m/s	
Rated operational characteristics (conforming to EN IEC 60947-5-1)	AC 15, A 300 / DC 13, Q 300		
Degree of protection conforming to IEC 60529	IP67		
Reliability data B_{10d}	5 000 000 value given for a service life of 20 years, limited by mechanical or contact wear		
Body + Head dimensions (mm) W x D x H	40 x 44 x 113.5 mm	52 x 44 x 113.5 mm	
Resistance to forcible withdrawal of actuator	20 N	1500 N	
Wiring connection	1 x ISO M20 entry	1 x PG13,5 entry	1 x ISO M20 1 x PG13,5 entry
Safety contacts	1NC+2NO break before make, slow break 2NC+1NO break before make, slow break 3NC slow break	XCSA502 ⊕ XCSA702 ⊕ XCSA802 ⊕	XCSA501 ⊕ XCSA701 ⊕ XCSA801 ⊕
		XCSB502 ⊕ XCSB702 ⊕ -	XCSC501 ⊕ XCSC701 ⊕ XCSC801 ⊕

- (3) Using an appropriate and correctly connected control system.

Accessoires

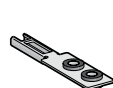

Straight actuator



Right-angled actuator



Pivoting actuator, RH door



Pivoting actuator, LH door

For safety switches XCSMP	Actuators			
References	XCSZ81	XCSZ84	XCSZ83	XCSZ85

For safety switches XCSPA/TA	Actuators				Retaining device
References	XCSZ11	XCSZ12	XCSZ14	XCSZ13	XCSZ21

- (4) For L = 29 mm, reference = XCSZ15.

ISO entry
(to EN 50262)

Illustration of contacts with the actuator inserted in the head of the switch

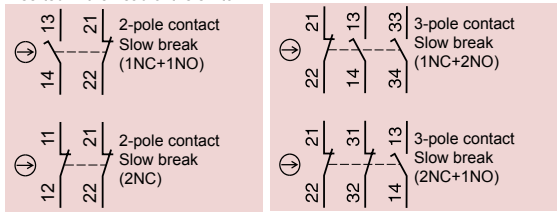

Safety interlock switches		Type XCSLF, metal		Type XCSLE, plastic	
Standard version and Connector version					
Maximum safety level (3)		PL=e, category 4 conforming to EN/ISO 13849-1 and SIL CL3 conforming to EN/IEC 62061			
Degree of protection conforming to IEC 60529		IP66 and IP67	IP65	IP66 and IP67	IP65
Reliability data B10d		5 500 000 value given for a service life of 20 years, limited by mechanical or contact wear			
Body + Head dimensions (mm) W x D x H		43,5 x 51 x 205 mm		43,5 x 51 x 205 mm	
Resistance to forcible withdrawal of actuator		3 000 N		1 400 N	
Locking		on de-energization (1)		on de-energization (1)	
Power supply for the solenoid and the LEDs		24VAC/DC			
Material case		Zamak		Polyamide	
Wiring connection (2)		3 x ISO M20	Connector M23 (4)	3 x ISO M20	Connector M23 (4)
Safety contacts	1NC+1NO (break before make, slow break)	XCSLF2525312	XCSLF252531M2	XCSLE2525312	XCSLE252531M2
	2NC (simultaneous, slow break)	XCSLF2727312	XCSLF272731M2	XCSLE2727312	XCSLE272731M2
	1NC+2NO (break before make, slow break)	XCSLF3535312	XCSLF353531M3	XCSLE3535312	XCSLE353531M3
	2NC+1NO (break before make, slow break)	XCSLF3737312	XCSLF373731M3	XCSLE3737312	XCSLE373731M3
	3NC (simultaneous, slow break)	XCSLF3838312	XCSLF383831M3	XCSLE3838312	XCSLE383831M3

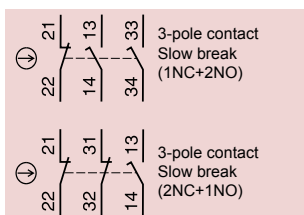

Illustration of contacts with the actuator inserted in the head of the switch



Safety interlock switches		Type XCSLF, metal			
Push button version and Push button with connector version					
Maximum safety level (3)		PL=e, category 4 conforming to EN/ISO 13849-1 and SIL CL3 conforming to EN/IEC 62061			
Degree of protection conforming to IEC 60529		IP66	IP65	IP66	IP65
Reliability data B10d		5 500 000 value given for a service life of 20 years, limited by mechanical or contact wear			
Body + Head dimensions (mm) W x D x H		43,5 x 51 x 205 mm			
Resistance to forcible withdrawal of actuator		3 000 N			
Locking		on de-energization (1)		on de-energization (1)	
Push button with or without key no. 455 to release		Without		With	
Power supply for the solenoid and the LEDs		24VAC/DC			
Material case		Zamak			
Wiring connection (2)		3 x ISO M20	Connector M23 (4)	3 x ISO M20	Connector M23 (4)
Safety contacts	1NC+2NO (break before make, slow break)	XCSLF3535412	XCSLF353541M3	XCSLF3535612	XCSLF353561M3
	2NC+1NO (break before make, slow break)	XCSLF3737412	XCSLF373741M3	XCSLF3737612	XCSLF373761M3

- (1) For locking on energisation of solenoid, please refer to www.tesensors.com
- (2) With cable entry for 1/2" NPT, please refer to www.tesensors.com
- (3) Using an appropriate and correctly connected control system.
- (4) M23 to XCSLF***M2 products: Connector M23, 16 pin
M23 to XCSLF***M3 products: Connector M23, 19 pin

Accessories

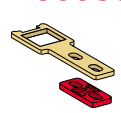

Straight actuator



Wide actuator

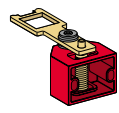

Pivoting actuator

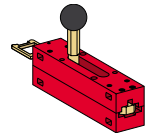

Door lock

For safety switches XCSA/B/C/LE/LF	Actuators			Door lock
References	XCSZ01	XCSZ02	XCSZ03	XCSZ05

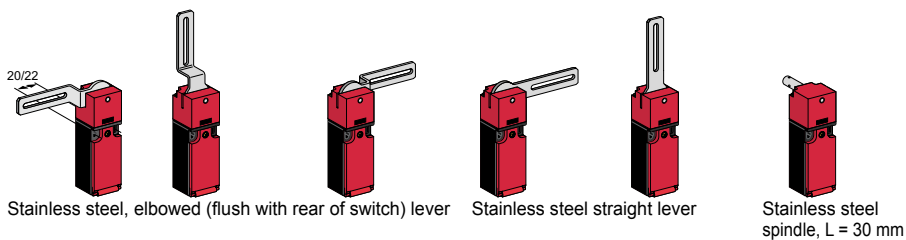
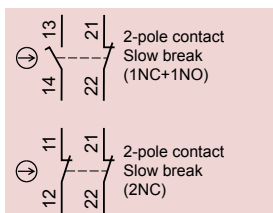

Plastic switches		Type XCSPL with rotary lever or XCSPL with spindle 1 x ISO M16 cable entry (1) (2)					
Maximum safety level (3)		PL=e, category 4 conforming to EN/ISO 13849-1 and SIL CL3 conforming to EN/IEC 62061					
Minimum torque (actuation / positive opening)		0,1 / 0,25 N.m					
Degree of protection		IP 67					
Rated operational characteristics (conforming to EN IEC 60947-5-1)		AC 15, A 300 / DC 13, Q 300					
Dimensions (body + head) W x D x H		30 x 30 x 160 mm					30 x 30 x 96 mm
Lever position		Lever to left	Lever centred	Lever to right	Lever to left or right	Lever centred	-
Tripping angle		5°					
Reliability data B10d		5 000 000 (value given for a service life of 20 years, limited by mechanical or contact wear)					
Complete switch	1NC+1NO break before make, slow break	XCSPL592 →	XCSPL582 →	XCSPL572 →	XCSPL562 →	XCSPL552 →	XCSPL552 →
	2NC slow break	XCSPL792 →	XCSPL782 →	XCSPL772 →	XCSPL762 →	XCSPL752 →	XCSPL752 →
	1NC+2NO break before make, slow break	-	-	-	XCSPL862 →	-	-
	2NC+1NO break before make, slow break	-	XCSPL982 →	-	XCSPL962 →	-	XCSPL952 →

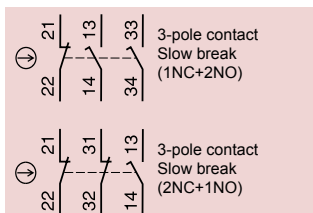

Plastic switches		Type XCSTL with rotary lever or XCSTR with spindle 2 x ISO M16 cable entries (2) (4)		
Maximum safety level (3)		PL=e, category 4 conforming to EN/ISO 13849-1 and SIL CL3 conforming to EN/IEC 62061		
Minimum torque (actuation / positive opening)		0.1 / 0.45 N.m		
Degree of protection		IP 67		
Rated operational characteristics (conforming to EN IEC 60947-5-1)		AC 15, A 300 / DC 13, Q 300		
Dimensions (body + head) W x P x H		52 x 30 x 180 mm		52 x 30 x 117 mm
Lever position		Lever centred	Lever centred	-
Tripping angle		5°		
Reliability data B10d		5 000 000 (value given for a service life of 20 years, limited by mechanical or contact wear)		
Complete switch	1NC+2NO break before make, slow break	XCSTL582 →	XCSTL552 →	XCSTR552 →
	2NC+1NO break before make, slow break	XCSTL782 →	XCSTL752 →	XCSTR752 →

(1) With entry for n° 11 (Pg 11) cable gland, replace the last digit in the reference by 1 (example: XCSPL592 becomes XCSPL591).

(2) For entry for ISO M20 cable gland, also order adaptor DE9RA1620 (sold in lots of 5).

(3) Using an appropriate and correctly connected control system.

(4) With entry for n° 11 (Pg 11) cable gland, replace the last digit in the reference by 1 (example: XCSTL582 becomes XCSTL581).

Limit switches

Safety limit switches

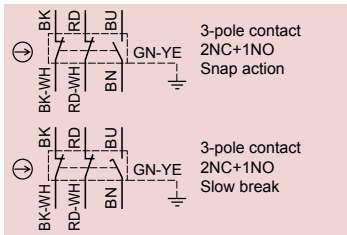

Metal end plunger



Roller plunger



Thermoplastic roller lever

Miniature switches	Type XCSM, metal pre-cabled, L = 1 m (1)		
Maximum safety level (2)	PL=e, category 4 conforming to EN/ISO 13849-1 and SIL CL3 conforming to EN/IEC 62061		
Maximum actuation speed	0.5 m/s	0.5 m/s	1.5 m/s
Minimum force or torque (actuation / positive opening)	8.5 N / 42.5 N	7 N / 35 N	0.5 N.m / 0.1 N.m
Degree of protection	IP 66 + IP 67 + IP 68	IP 66 + IP 67 + IP 68	IP 66 + IP 67 + IP 68
Dimensions (body + head) W x D x H	30 x 16 x 60 mm	30 x 16 x 70.5 mm	30 x 32 x 92.5 mm
Reliability data B10d	50 000 000 (value given for a service life of 20 years, limited by mechanical or contact wear)		
Complete switch	2NC+1NO snap action	XCSM3910L1 (2)	XCSM3902L1 (2)
	2NC+1NO slow break	XCSM3710L1 (2)	XCSM3702L1 (2)

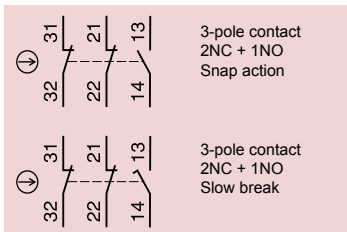

Metal end plunger



Roller plunger



Thermoplastic roller lever



Metal end plunger



Roller plunger



Thermoplastic roller lever

Compact switches	Type XCSD, metal 1 x ISO M20 x 1.5 cable entry (3)			Type XCSP, plastic 1 x ISO M20 x 1.5 cable entry (2)		
	Maximum safety level (2)	PL=e, category 4 conforming to EN/ISO 13849-1 and SIL CL3 conforming to EN/IEC 62061				
Maximum actuation speed	0.5 m/s	1.5 m/s	0.5 m/s	0.5 m/s	1.5 m/s	1.5 m/s
Minimum force or torque (actuation / positive opening)	15 N / 45 N	12 N / 36 N	10 N.m / 0.1 N.m	15 N / 45 N	12 N / 36 N	10 N.m / 0.1 N.m
Degree of protection	IP 66 + IP 67			IP 66 + IP 67		
Dimensions (body + head) W x D x H (mm)	34 x 34.5 x 89	34 x 34.5 x 99.5	34 x 43 x 121.5	34 x 34.5 x 89	34 x 34.5 x 99.5	34 x 43 x 121.5
Reliability data B10d	50 000 000 (value given for a service life of 20 years, limited by mechanical or contact wear)					
Complete switch	2NC+1NO snap action	XCSD3910P20	XCSD3902P20	XCSD3918P20	XCSP3910P20	XCSP3902P20
	2NC+1NO slow break	XCSD3710P20	XCSD3702P20	XCSD3718P20	XCSP3710P20	XCSP3702P20

(1) For a 2 m long cable, replace the last digit of the reference by 2 (example: XCSM3910L1 becomes XCSM3910L2).

For a 5 m long cable, replace the last digit of the reference by 5 (example: XCSM3910L1 becomes XCSM3910L5).

(2) Using an appropriate and correctly connected control system.

(3) For Pg 13.5 and 1/2" NPT cable entries, refer to www.tesensors.com.

(1)

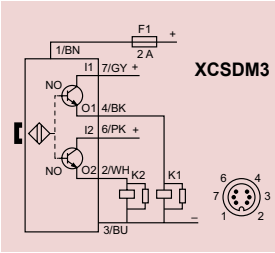

(1)

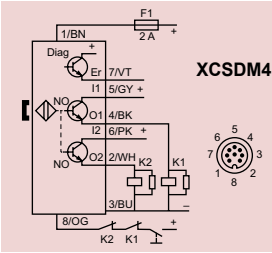

Type of system		SIL2/Category 3	SIL3/Category 4	
With integrated safety module		XCSDM3	XCSDM4	
Maximum safety level		SIL 2 conforming to EN/IEC 61508, PL=d, category 3 conforming to EN/ISO 13849-1	SIL 3 conforming to EN/IEC 61508, PL=e, category 4 conforming to EN/ISO 13849-1	
Switches for actuation		Face to face, face to side, side to side		
Degree of protection		Pre-cabled: IP66 / IP67, IP69K, connector: IP67		
Type of contact		2 solid-state output PNP/NO, 1,5 A / 24VDC (2 A up to 60°C)		
Rated operational characteristics (conforming to EN IEC 60947-5-1)		Ub: 24 VDC +10% - 20%		
Dimensions W x D x H		34 x 27 x 100 mm		
Operating zone		Sao= 10 mm / Sar= 20 mm		
Reliability data		MTTFd = 182 years; PFH = 3.94E -9; PFD = 1.15E -5; SFF = 92.5%; HFT = 1		
References	Connection	for cable L= 2m	XCSDM379102	XCSDM480102
		for cable L= 5m	XCSDM379105	XCSDM480105
		for cable L= 10m	XCSDM379110	XCSDM480110
		for connector M12	XCSDM3791M12	XCSDM4801M12

Plastic coded magnetic

(1)

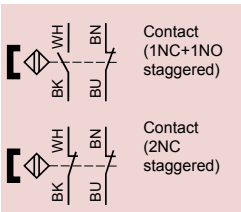

(1)

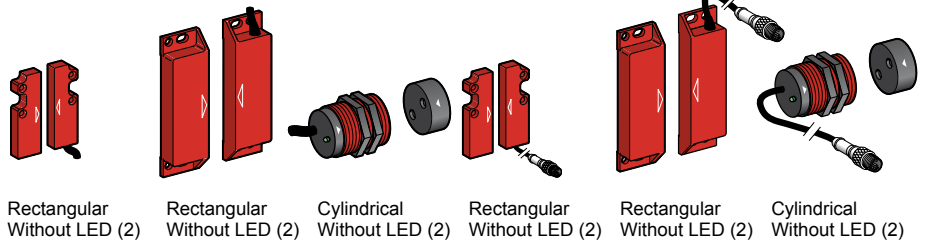
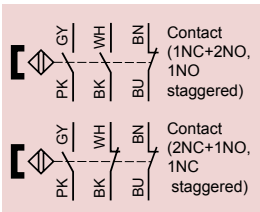

Plastic switches	Type XCSDM coded magnetic				
	Pre-cabled, L = 2 m			Connector on flying lead, L = 15 cm (3)	
Maximum safety level (5)	PL=e, category 4 conforming to EN/ISO 13849-1 and SIL 3 conforming to EN/IEC 61508				
Switches for actuation	Face to face, face to side, side to side		Face to face	Face to face, face to side, side to side	
Degree of protection	IP 66 + IP 67			IP 66 + IP 67	
Type of contact	REED				
Rated operational characteristics (conforming to EN IEC 60947-5-1)	Ue = 24 VDC, Ie = 100 mA				
Dimensions W x D x H	16 x 7 x 51 mm	25 x 13 x 88 mm	M30 x 38,5 mm	16 x 7 x 51 mm	25 x 13 x 88 mm
Operating zone (4)	Sao = 5 / Sar = 15		Sao = 8 / Sar = 20	Sao = 5 / Sar = 15	
Reliability data B10d	50 000 000 (value given for a service life of 20 years, limited by mechanical or contact wear)				
Switch with coded magnet	1NC+1NO staggered	XCSDMC5902	XCSDMP5902	XCSDMR5902	XCSDMC590L01M8
	2NC staggered	XCSDMC7902	XCSDMP7902	XCSDMR7902	XCSDMC790L01M8
	1NC+2NO, 1NO staggered	—	XCSDMP5002	—	XCSDMP500L01M12
	2NC+1NO, 1NC staggered	—	XCSDMP7002	—	XCSDMP700L01M12

(1) Illustration of contacts with the magnet in front of the switch.

(2) For version with LED indicator, replace the last 0 in the reference by 1 (example: XCSDMC5902 becomes XCSDMC5912).

(3) For associated pre-wired female connectors, please refer to the "Preventa XCS safety switches" catalogue.

(4) Sao: assured operating distance. Sar: assured release distance.

(5) Using an appropriate and correctly connected control system

Emergency stops

Emergency stop rope pull switches

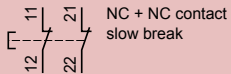
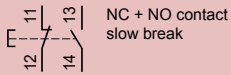

For operating cable length < 20 - 30m		Latching, without indicator light		
		Pg 13.5 threaded cable entry		
Maximum safety level (2)		PL e, category 4 conforming to EN/ISO 13849-1 and SIL CL3 conforming to EN/IEC 62061		
Mechanical life		100, 000 operating cycles		
Shock / vibration resistance		50 gn / 10 gn		
Degree of protection		IP 66 and 67		
Conformity to standards		EN/IEC 60947-5-5, EN/ISO 13850, UL (NiSD) - CSA, CCC		
Dimensions W x D x H		200,9 x 40 x 64,2 mm		
Operating cable length		< 20 m	< 30 m	< 30 m
Operating cable anchoring point		straight	right side	left side
Reliability data B10d		500, 000 (value given for a service life of 20 years, limited by mechanical or contact wear)		
Contact	1 NC + NO slow break	XY2CJS15 (4)	XY2CJR15 (4)	XY2CJL15 (4)
	1 NC + NC slow break	XY2CJS17 (4)	XY2CJR17 (4)	XY2CJL17 (4)
	2 NC + 1 NO slow break	XY2CJS19 (4) (5)	XY2CJR19 (4) (5)	XY2CJL19 (4) (5)



Booted pushbutton reset



Key release pushbutton reset (key n° 421)



For operating cable length ≤ 30 m		Latching, without indicator light		with indicator light
		3 x ISO M20 cable entries (1)		
Maximum safety level (2)		PL=e, category 4 conforming to EN/ISO 13849-1 and SIL 3 conforming to EN/IEC 61508		
Mechanical life		800 000 operating cycles		
Shock / vibration resistance		50 gn / 10 gn		
Degree of protection		IP 65		
Conformity to standards		EN/IEC 60947-5-5, EN/ISO 13850: 2006, UL 508 and CSA C 22-2 n° 14 (with suffix H7)		
Dimensions W x D x H		201 x 71 x 68 mm		
Operating cable length		≤ 30 m		
Operating cable anchoring point		To right or to left		
Reliability data B10d		4 000 000 (value given for a service life of 20 years, limited by mechanical or contact wear)		
Contact	1 NC + NO slow break	XY2CH13250H29	XY2CH13450H29	XY2CH13253
	1 NC + NC slow break	XY2CH13270H29	XY2CH13470H29	XY2CH13273
	2 NC + 1 NO slow break	XY2CH13290H29	-	XY2CH13293H29



Booted pushbutton reset



Key release pushbutton reset (key n° 421)

For operating cable length ≤ 70 m		Latching, without indicator light			
		3 plain holes with Pg13,5 cable entries			
Maximum safety level (2)		PL=e, category 4 conforming to EN/ISO 13849-1 and SIL 3 conforming to EN/IEC 61508			
Mechanical life (millions of operating cycles)		0.01			
Shock / vibration resistance		50 gn / 10 gn			
Degree of protection		IP 65			
Conformity to standards		EN/IEC 60947-5-5, EN/ISO 13850: 2006, UL 508 and CSA C 22-2 n° 14 (with suffix H7)			
Dimensions W x D x H		229 x 82 x 142 mm			
Operating cable length		≤ 70 m			
Operating cable anchoring point		To left	To right	To left	To right
Reliability data B10d		50.000 (value given for a service life of 20 years, limited by mechanical or contact wear)			
Contact	1 NC + NO slow break	XY2CE2A250	XY2CE1A250	XY2CE2A450	XY2CE1A450
	1 NC + NC slow break	XY2CE2A270	XY2CE1A270	XY2CE2A470	XY2CE1A470
	2 NC + NO slow break	XY2CE2A290 (3)	XY2CE1A290 (3)	XY2CE2A490 (3)	XY2CE1A290 (3)

(1) With entry for n° 13 (Pg 13.5) cable gland, delete H29 from the end of the reference (example: XY2-CH13250H29 becomes XY2-CH13250). (2) Using an appropriate and correctly connected control system. (3) With protected LED, 24V or 130 V supply voltage pilot light, add 6 at the end of the reference. (example: XY2CE1A290 becomes XY2CE1A296). With protected LED, 230 V supply voltage pilot light, add 7 at the end of the reference. (example: XY2CE1A290 becomes XY2CE1A297). (4) For ISO M20 threaded cable entry version, add H29 to the end of the reference selected. Example: XY2CJS15 becomes XY2CJS15H29. (5) For 1/2" NPT threaded cable entry version, add H7 to the end of the reference selected. Example: XY2CJS19 becomes XY2CJS19H7.



Main features (1)

- Automatic or Manual Start/Restart selectable by wiring
- External Device Monitoring (EDM) selectable by wiring
- Two maximum Sensing Distance selectable by wiring
- Test function (beam blocked state simulation)
- Led indicators for status and diagnosis
- Muting possible with dedicated Safety module

Maximum safety level achieved by the solution EN ISO 13849-1		PLd/cat2	
Maximum safety level achieved by the solution IEC 61508/IEC 62061		SIL2/SILCL2	
Type IEC 61496-1 & IEC 61496-2		Type 2 Multi-beam, infrared transmission	
Nominal sensing distance (Sn)		0...4 m or 0...12 m selectable	
Resolution (detection capability)		30 mm (Hand detection)	2-3 or 4 Beams (Body Detection)
Number of safety outputs		2 solid-state PNP	
Response time (depending on model)		4.5...23.5 ms	3...3.5 ms
Operating temperature range		-10°C...+55°C	
Degree of protection		IP65-IP67	
Connection		M12 Connector	
Reliability data		PFHd = 2.04E-8 to 8.98E-8	PFHd = 1.71E-8 to 2.02E-8
Mission time		TM = 20 years	
Height protected (mm)	160	XUSL2E30H016N	–
	260	XUSL2E30H026N	–
	310	XUSL2E30H031N	–
	460	XUSL2E30H046N	–
	510 - 2 beams	–	XUSL2E2BB051N
	610	XUSL2E30H061N	–
	760	XUSL2E30H076N	–
	810 - 3 beams	–	XUSL2E3BB081N
	910	XUSL2E30H091N	–
	910 - 4 beams	–	XUSL2E4BB091N
	1060	XUSL2E30H106N	–
	1210	XUSL2E30H121N	–
	1360	XUSL2E30H136N	–
	1510	XUSL2E30H151N	–
	1660	XUSL2E30H166N	–
	1810	XUSL2E30H181N	–

Type 2 conforming to IEC 61496-1 et 2

Light curtain functions

- Auto/Manual,
- Monitoring of external switching devices (EDM: External Devices Monitoring),
- LED display of operating modes
- Integral muting function.



Maximum safety level achieved by the solution (EN ISO 13849-1, EN/IEC 62061)		PLc/cat2, SILCL1	
Type		Single-beam with infrared emission	
Height protected (conforming to prEN 999)		750...1200 mm (1 to 4 beams)	
Nominal sensing distance (Sn)		8 m	
Number of circuits	Safety	2N/O	
	Additional	4 solid-state	
Response time		< 25 ms	
Reliability data		PFHd = 4.6E -7 conforming to EN/IEC 61508 PFHd = 5.5E -7 conforming to EN/IEC 61508, with "muting" function	
Modules (integral muting function)		24 VDC	XPSCM1144P (2)
Thru-beam pairs, axially aligned	Pre-cabled, L = 5m	PNP	XU2S18PP340L5 (3)
	M12 connector	PNP	XU2S18PP340D (3)

(1) Also exists in IP69k model. (2) For version with non removable terminal block, delete the letter P from the end of the reference. Example: XPSCM1144P becomes XPSCM1144).
(3) For alignment at 90° to the mounting axes, insert the letter W in the reference before the last letter. Example: XU2S18PP340L5 becomes XU2S18PP340WL5).

Type 4 conforming to IEC 61496-1 & IEC 61496-2



Main features (1)

- Automatic or Manual Start/Restart selectable by wiring
- External Device Monitoring (EDM) selectable by wiring
- Two maximum Sensing Distance selectable by wiring
- Test function (beam blocked state simulation)
- Led indicators for status and diagnosis
- Muting possible with dedicated Safety module

Maximum Safety level achieved by the solution EN ISO 13849-1		PLe/cat4		
Maximum Safety level achieved by the solution IEC 61508/IEC 62061		SIL3/SILCL3		
Type IEC 61496-1 & IEC 61496-2		Type4 Multi-beam, infrared transmission		
Nominal sensing distance (Sn)		0...3 m or 1...6 m selectable	0...4 m or 0...12 m selectable	0...4 m or 0...12 m selectable
Resolution (detection capability)		14 mm (Finger detection)	30 mm (Hand detection)	2-3 or 4 Beams (Body Detection)
Number of safety outputs		2 solid-state PNP		
Response time (depending on model)		4...23.5 ms	4...22 ms	2.5...3 ms
Operating temperature range		-10°C...+55°C		
Degree of protection		IP65-IP67		
Connection		M12 Connector		
Reliability data (depending on model) conforming to EN/IEC 61508		PFHd = 1.03E-8 to 3.71E-8	PFHd = 7.08E-9 to 2.02E-8	PFHd = 6.89E-9 to 8.21E-9
Mission time		TM = 20 years		
Height protected (mm)	160	XUSL4E14F016N	XUSL4E30H016N	–
	260	–	XUSL4E30H026N	–
	310	XUSL4E14F031N	XUSL4E30H031N	–
	460	XUSL4E14F046N	XUSL4E30H046N	–
	510 - 2 beams	–	–	XUSL4E2BB051N
	610	XUSL4E14F061N	XUSL4E30H061N	–
	760	XUSL4E14F076N	XUSL4E30H076N	–
	810 - 3 beams	–	–	XUSL4E3BB081N
	910	XUSL4E14F091N	XUSL4E30H091N	–
	910 - 4 beams	–	–	XUSL4E4BB091N
	1060	XUSL4E14F106N	XUSL4E30H106N	–
	1210	XUSL4E14F121N	XUSL4E30H121N	–
	1360	XUSL4E14F136N	XUSL4E30H136N	–
	1510	XUSL4E14F151N	XUSL4E30H151N	–
	1660	XUSL4E14F166N	XUSL4E30H166N	–
	1810	XUSL4E14F181N	XUSL4E30H181N	–

Type		Long Range models		
		For hand and body protection		
Nominal sensing distance (Sn)		0...10 m or 3...20 m selectable		0...10 m or 3...20 m selectable
Reliability data (depending on model) conforming to EN/IEC 61508		PFHd = 9.13E-9 to 2.29E-8		PFHd = 9.15E-9 to 1.08E-8
Response time (depending on model)		3...13 ms		2.5 ms
Height protected (mm)	160	XUSL4E30H016L		–
	310	XUSL4E30H031L		–
	460	XUSL4E30H046L		–
	510 - 2 beams	–		XUSL4E2BB051L
	610	XUSL4E30H061L		–
	760	XUSL4E30H076L		–
	810 - 3 beams	–		XUSL4E3BB081L
	910	XUSL4E30H091L		–
	910 - 4 beams	–		XUSL4E4BB091L
	1060	XUSL4E30H106L		–
	1210	XUSL4E30H121L		–
	1360	XUSL4E30H136L		–
	1510	XUSL4E30H151L		–
	1660	XUSL4E30H166L		–
	1810	XUSL4E30H181L		–

(1) Also exists in IP69K model.



Main features (1)

- Automatic or Manual Start/Restart selectable by wiring
- External Device Monitoring (EDM) selectable by wiring
- Two maximum Sensing Distance selectable by wiring
- Test function (beam blocked state simulation)
- Led indicators for status and diagnosis
- Muting possible with dedicated Safety module

Type		Cascadable models - Master Segments (2)		
Nominal sensing distance (Sn)		0...3 m or 1...6 m selectable	0...4 m or 0...12 m selectable	0...4 m or 0...12 m selectable
Resolution (detection capability)		14 mm (Finger detection)	30 mm (Hand detection)	2-3 or 4 Beams (Body Detection)
Number of safety outputs		2 solid-state PNP		
Response time		Depends on the number and the model of segments used. See the "User Manual" for the calculation		
Operating temperature range		-10°C...+55°C		
Degree of protection		IP65-IP67		
Connection		2xM12 Connector		
Reliability data (depending on model)conforming to EN/IEC 61508		PFHd = 1.27E-8 to 2E-8	PFHd = 9.47E-9 to 1.43E-8	PFHd = 6.89E-9 to 8.21E-9
Mission time		TM = 20 years		
Height protected (mm) (2)	310	XUSL4E14F031NM	–	–
	460	XUSL4E14F046NM	XUSL4E30H046NM	–
	510 - 2 beams	–	–	XUSL4E2BB051NM
	610	XUSL4E14F061NM	XUSL4E30H061NM	–
	760	XUSL4E14F076NM	XUSL4E30H076NM	–
	810 - 3 beams	–	–	XUSL4E3BB081NM
	910	–	XUSL4E30H091NM	–
	910 - 4 beams	–	–	XUSL4E4BB091NM
	1060	–	XUSL4E30H106NM	–

Type		Cascadable models - Slave1 Segments (2)		
Reliability data (depending on model) conforming to EN/IEC 61508		PFHd = 1.27E-8 to 2E-8	PFHd = 9.47E-9 to 1.43E-8	PFHd = 6.89E-9 to 8.21E-9
Response time		Depends on the number and the models of segments used. See the "User Manual" for the calculation		
Connection		M12 Connector		
Height protected (mm) (1)	310	XUSL4E14F031NS1	–	–
	460	XUSL4E14F046NS1	XUSL4E30H046NS1	–
	510 - 2 beams	–	–	XUSL4E2BB051NS1
	610	XUSL4E14F061NS1	XUSL4E30H061NS1	–
	760	XUSL4E14F076NS1	XUSL4E30H076NS1	–
	810 - 3 beams	–	–	XUSL4E3BB081NS1
	910	–	XUSL4E30H091NS1	–
	910 - 4 beams	–	–	XUSL4E4BB091NS1
	1060	–	XUSL4E30H106NS1	–

Type		Cascadable models - Slave2 Segments (2)		
Reliability data (depending on model) conforming to EN/IEC 61508		PFHd = 1.52E-8 to 2E-8	PFHd = 9.47E-9 to 1.43E-8	PFHd = 6.89E-9 to 8.21E-9
Response time		Depends on the number and the models of segments used. See the "User Manual" for the calculation		
Connection		2xM12 Connector		
Height protected (mm) (1)	310	–	–	–
	460	XUSL4E14F046NS2	XUSL4E30H046NS2	–
	510 - 2 beams	–	–	XUSL4E2BB051NS2
	610	XUSL4E14F061NS2	XUSL4E30H061NS2	–
	760	XUSL4E14F076NS2	XUSL4E30H076NS2	–
	810 - 3 beams	–	–	XUSL4E3BB081NS2
	910	–	XUSL4E30H091NS2	–
	910 - 4 beams	–	–	XUSL4E4BB091NS2
	1060	–	XUSL4E30H106NS2	–

(1) Other Heights available on request

(2) cable sold separately, please refer to Page 65

Cabling accessories

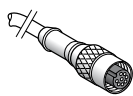

XZCP29P11L●●

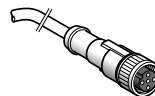

XZCP1164L●



XZCP1264L●

Type			M12 connector - Pre-wired				
Cable length			2 m	5 m	10 m	15 m	25 m
M12 connector 5 pins Female	Straight - Pre-wired	For transmitter	XZCP1164L2	XZCP1164L5	XZCP1164L10	XZCP1164L15	XZCP1164L25
	90° - Pre-wired	For transmitter	XZCP1264L2	XZCP1264L5	XZCP1264L10	XZCP1264L15	XZCP1264L25
M12 connector 8 pins Female	Straight - Pre-wired	For receiver	XZCP29P11L2	XZCP29P11L5	XZCP29P11L10	XZCP29P11L15	XZCP29P11L25
	90° - Pre-wired	For receiver	XZCP53P11L2	XZCP53P11L5	XZCP53P11L10	XZCP53P11L15	XZCP53P11L25

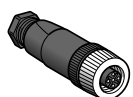

XZCC12FDM50B



XZCC12FCM50B

Type			M12 connector - with screw terminals				
Cable length			2 m				
M12 connector 5 pins Female	90° - 5 poles with screw terminals- cable gland	For transmitter	XZCC12FCM50B				
	Straight - 5 poles with screw terminals- cable gland	For transmitter	XZCC12FDM50B				
M12 connector 8 pins Female	90° - 8 poles with screw terminals- cable gland	For receiver	XZCC12FCM80B				
	Straight - 8 poles with screw terminals- cable gland	For receiver	XZCC12FDM80B				

Type			2xM12 connectors - Jumpers				
Cable length			0.3 m	3 m	5 m	10 m	25 m
2 straight M12 - Female/Female connectors - 5 poles	For Master/Slave cascable segments		XZCR1111064D03	XZCR1111064D3	XZCR1111064D5	XZCR1111064D10	XZCR1111064D25

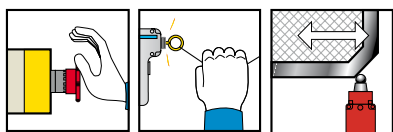

Maximum safety level of the solution attained (EN ISO 13849-1, EN/IEC 62061)		PL e / Cat. 4, SILCL 3							
Number of circuits	Safety	3 N/O	3 N/O	3 N/O	3 N/O	7 N/O	3 N/O + 3 N/O time del.	2 N/O + 1 N/O time del.	2 N/O + 3 N/O time del.
	Additional	1 solid-state	1 N/C	-	1 N/C + 4 solid-state	2 N/C + 4 solid-state	3 solid-state	-	4 solid-state
Display (number of LEDs)		2	2	3	4	4	11	3	4
Width of housing		22.5 mm	22.5 mm	22.5 mm	45 mm	90 mm	45 mm	22.5 mm	45 mm

Optimum solutions: safety modules (for monitoring 1 safety function)

Supply voltage (1)	24 VDC	-	-	-	-	-	XPSAV11113P	XPSABV11330P (2)	-
	24 VAC/DC	XPSAC5121P	XPSAXE5120P (2)	XPSAF5130P	XPSAK311144P	XPSAR311144P	-	-	XPSATE5110P
	230 VAC	-	-	-	-	-	-	-	XPSATE3710P

(1) For version with non removable terminal block, delete the letter **P** from the end of the reference (example: XPSAV11113P becomes XPSAV11113).

(2) For a version with spring terminals, replace the letter **P** with the letter **C** at the end of the reference (example: XPSAXE5120P becomes XPSAXE5120C).

coded magnetic switches

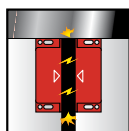

Maximum safety level of the solution attained (EN ISO 13849-1, EN/IEC 62061)		PL e / Cat. 4, SILCL 3		
For monitoring		2 coded magnetic switches maximum N/C + N/O	6 coded magnetic switches maximum N/C + N/O	6 coded magnetic switches maximum 2 N/C
Number of circuits	Safety	2 N/O	2 N/O	3 N/O
	Additional	2 solid-state	2 solid-state	-
Display (number of LEDs)		3	15	3
Width of housing		22.5 mm	45 mm	22.5 mm

Optimum solutions: safety modules (for monitoring 1 safety function)

Supply voltage	24 VDC	XPSDMB1132P (1)	XPSDME1132P (1)	XPSVC1132P (1)
----------------	--------	-----------------	-----------------	----------------

(1) For version with non removable terminal block, delete the letter **P** from the end of the reference (example: XPSDMB1132P becomes XPSDMB1132).

Safety modules for monitoring light curtains

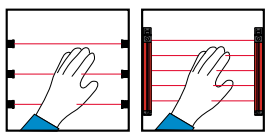

Maximum safety level of the solution attained (EN ISO 13849-1, EN/IEC 62061)		PL c / Cat. 2, SILCL 1		PL e / Cat. 4, SILCL 3	
Number of circuits	Safety	2 N/O	3 N/O	3 N/O	7 N/O
	Additional	4 solid-state	–	1 N/C + 4 solid-state	1 N/C + 4 solid-state
Display (number of LEDs)		4	3	4	4
Width of housing		45 mm	22.5 mm	45 mm	90 mm
Integral Muting function		Yes	No	No	No

Optimum solutions: safety modules (for monitoring 1 safety function)

Supply voltage	24 VDC	XPSCM1144P (1)	–	–	–
	24 VAC/DC	–	XPSAFL5130P (1)	XPSAK311144P (1)	XPSAR311144P (1)

(1) For version with non removable terminal block, delete the letter P from the end of the reference (example: XPSCM1144P becomes XPSCM1144).

zero speed, time delay and lifts

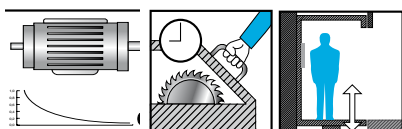

Maximum safety level of the solution attained (EN ISO 13849-1, EN/IEC 62061)		PL d / Cat. 3, SILCL 2		PL e / Cat. 4, SILCL 3	
For monitoring		Motor zero speed condition	Safety time delay		Lifts
Number of circuits	Safety	1 N/O + 1 N/C	1 N/O time delay	1 N/O pulse	2 N/O
	Additional	2 solid-state	2 N/C + 2 solid-state	2 N/C + 2 solid-state	2 solid-state
Display (number of LEDs)		4	4	4	4
Width of housing		45 mm	45 mm	45 mm	22.5 mm

Optimum solutions: safety modules (for monitoring 1 safety function)

Supply voltage	24 VDC	XPSVNE1142P (1)	–	–	–
	24 VAC/DC	–	XPSTSA5142P (2)	XPSTSW5142P (2)	XPSEDA5142

(1) Motor frequency ≤ 60 Hz.. For frequencies ≥ 60 Hz, please refer to the "Safety solution" catalogue.

(2) Removable terminal block version only.

Main sectors of activity subject to a higher risk of explosion or fire

Flour mills



Wood and aluminium workshops



Bagging



Grain silos



Grain drying areas



Bulk conveying



Explosive atmospheres

A reference for installations in ATEX Dust explosive atmospheres.



What is an explosive atmosphere according to the Directive?

It is the mixing with air, in atmospheric conditions, of flammable substances in the form of gas, vapour, mist or dust which, in the event of combustion, spreads throughout the non burning mix.

Implementation of European Directives

- *Directive 99/92/EC*

This requires that a risk analysis be performed for all industrial processes. If there is any risk of an explosion:

- the zones are defined and physically identified,
- the installation is classified by governing bodies.

- *Directive 94/9/EC*

This requires certification of the products in accordance with the classification of the zones of use

- *Dust zones*

- Zone 20: area where an explosive atmosphere exists in the form of combustible clouds of dust in the air, either permanently, for long periods or frequently.
- Zone 21: area where an explosive atmosphere exists in the form of combustible clouds of dust in the air during normal operation occasionally.
- Zone 22: area where an explosive atmosphere in the form of combustible clouds of dust in the air is unlikely to occur during normal operation but, if it does occur, it is only for a short period.

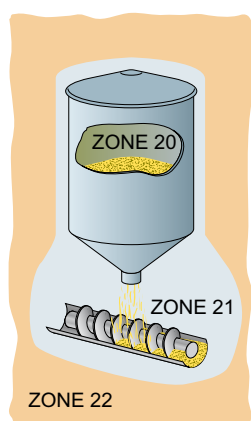

A selection of certified products, conforming to the European Directive ATEX94/9/EC, to ensure maximum safety for your installations in a zone where the risk of explosion or fire is high.

The products in this catalogue are certified by a European Union Commission notified body.



OsiSense XC

Limit switches Miniature, fixing by the body



Limit switch type	XCMD metal, pre-cabled			
With head for movement	Linear (plunger)			
Conformity	Directive ATEX 94/9/EC, EN/IEC 60079-0, EN/IEC 60079-31			
Zone D (dust)	21 - 22			
EC type examination certificate number / marking	INERIS 04ATEX0014X / II2 D-Ex tb III C T85°C Db IP66/67			
Type of operator	Metal end plunger	Metal end plunger with elastomer boot	Steel roller plunger	Retractable steel roller lever plunger
Mechanical durability (millions of operating cycles)	10			
Actuation speed	0.5 m/s			
Switches conforming to standard IEC 947-5-1 section 3	⊕			
Temperature range	- 20...+ 60°C			
Degree of protection (conforming to IEC 60529)	IP66 and IP67			
Rated operational characteristics (conforming to EN IEC 60947-5-1)	AC15; C300 (Ue = 240 V, Ie = 0.75 A)/DC13; R300 (Ue = 250 V, Ie = 0.1 A)			
Short-circuit protection	By 6 A cartridge fuse type gG (gl)			
Cable entry	Pre-cabled, adjustable direction, length = 5 m			
Fixing centres	20 mm			
Body dimensions, W x D x H	30 x 16 x 50 mm			
References	2NC+2NO snap action	XCMD4110L5EX	XCMD4111L5EX	XCMD4102L5EX XCMD4124L5EX

Compact, fixing by the body



Limit switch type	XCKD metal conforming to standard EN 500047				
With head for movement	Linear (plunger)				
Conformity	Directive ATEX 94/9/EC, EN/IEC 60079-0, EN/IEC 60079-31				
Zone D (dust)	21 - 22				
EC type examination certificate number / marking	INERIS 04ATEX0014X / II2 D-Ex tb III C T85°C Db IP66/67				
Type of operator	Metal end plunger	Metal end plunger with elastomer boot	Steel roller plunger	Thermoplastic roller lever plunger, horiz. actuation in 1 direct.	Thermoplastic roller lever plunger, vert. actuation in 1 direct.
Mechanical durability (millions of operating cycles)	15		10	15	
Actuation speed	0.5 m/s			1 m/s	
Switches conforming to standard IEC 947-5-1 section 3	⊕				
Temperature range	- 20...+ 60°C				
Degree of protection (conforming to IEC 60529)	IP66 and IP67				
Rated operational characteristics (conforming to EN IEC 60947-5-1)	AC15; B300 (Ue = 240 V, Ie = 1.5 A)/DC13; R300 (Ue = 250 V, Ie = 0.1 A)				
Short-circuit protection	By 6 A cartridge fuse type gG (gl)				
Cable entry	1 entry fitted with ISO M16 cable gland				
Fixing centres	20 mm				
Body dimensions, W x D x H	31 x 30 x 65 mm				
References	2NC+1NO snap action	XCKD3910P16EX	XCKD3911P16EX	XCKD3902P16EX	XCKD3921P16EX XCKD3927P16EX

Other characteristics: please refer to the "Detection for OsiSense automation solutions" catalog

Miniature, fixing by the head



XCMD metal, pre-cabled Rotary (lever)				Linear (plunger)		
Directive ATEX 94/9/EC, EN/IEC 60079-0, EN/IEC 60079-31						
21 - 22						
INERIS 04ATEX0014X / II 2 D-Ex tb III C T85°C Db IP66/67						
Steel roller lever	Thermoplastic roller lever	Roller lever with ball bearing mounted roller	Variable length thermoplastic roller lever	M12 with metal end plunger	M16 with metal end plunger with elastomer boot	M12 with steel roller plunger
10						
1.5 m/s				0.5 m/s		0.1 m/s
- 20...+ 60°C						
IP66 and IP67						
AC15; C300 (Ue = 240 V, Ie = 0.75 A)/DC13; R300 (Ue = 250 V, Ie = 0.1 A)						
By 6 A cartridge fuse type gG (gl)						
Pre-cabled, adjustable direction, length = 5 m						
20 mm				M12 x 1	M16 x 1	M12 x 1
30 x 16 x 50 mm						
XCMD4116L5EX	XCMD4115L5EX	XCMD4117L5EX	XCMD4145L5EX	XCMD41F0L5EX	XCMD41G1L5EX	XCMD41F2L5EX

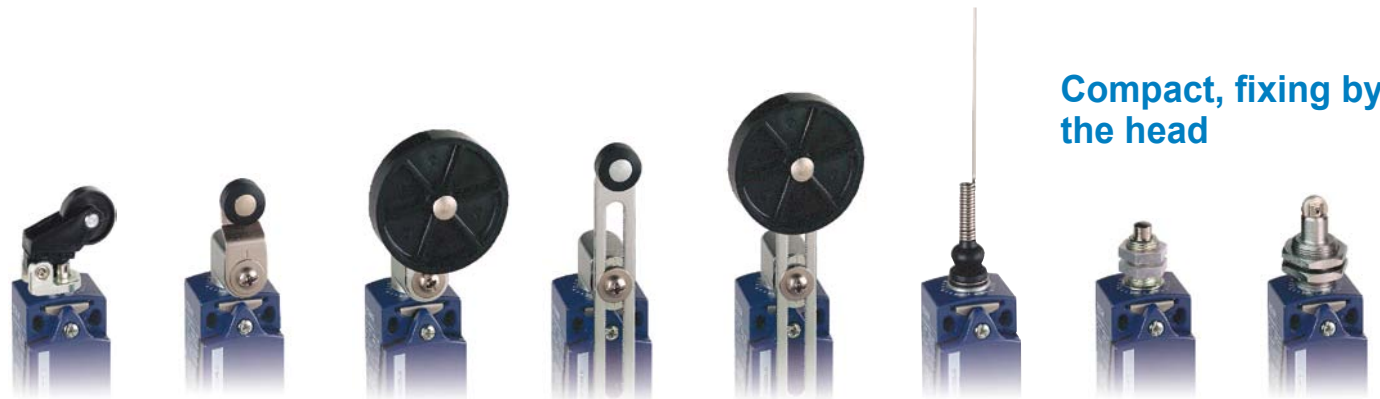

Compact, fixing by the head

XCKD metal conforming to standard EN 500047 Linear (plunger) Rotary (lever)				Multi-directional		Linear (plunger)	
Directive ATEX 94/9/EC, EN/IEC 60079-0, EN/IEC 60079-31							
21 - 22							
INERIS 04ATEX0014X / II 2 D-Ex tb III C T85°C Db IP66/67							
Thermoplastic roller lever plunger, horiz. or vert. actuation in 1 dir.	Thermoplastic roller lever	Thermoplastic roller lever, Ø 50 mm	Variable length thermoplastic roller lever	Variable length thermoplastic roller lever, Ø 50 mm	"Cat's whisker"	M18 with metal end plunger	M18 with steel roller plunger
15	10				5	10	
1 m/s	1.5 m/s				1 m/s	0.5 m/s	
					-		
- 20...+ 60°C							
IP66 and IP67							
AC15; B300 (Ue = 240 V, Ie = 1.5 A)/DC13; R300 (Ue = 250 V, Ie = 0.1 A)							
By 6 A cartridge fuse type gG (gl)							
1 entry fitted with ISO M16 cable gland							
20 mm						M18 x 1	
30 x 16 x 50 mm							
XCKD3928P16EX	XCKD3918P16EX	XCKD3939P16EX	XCKD3945P16EX	XCKD3949P16EX	XCKD3906P16EX	XCKD39H0P16EX	XCKD39H2P16EX



OsiSense XC

Limit switches

Classic, fixing by the body



Limit switch type	XCKM metal, 3 cable entries				
With head for movement	Linear (plunger)		Rotary (lever)	Multi-directional	
Conformity	Directive ATEX 94/9/EC, EN/IEC 60079-0, EN/IEC 60079-31				
Zone D (dust)	21 - 22				
EC type examination certificate number / marking	INERIS 04ATEX0014X / II 2 D-Ex tb III C T85°C Db IP66/67				
Type of operator	Metal end plunger	Steel roller plunger	Thermoplastic roller lever plunger, horiz. actuation in 1 direct.	Thermoplastic roller lever	"Cat's whisker"
Mechanical durability (millions of operating cycles)	20			10	
Actuation speed	0.5 m/s		1.5 m/s		0.5 m/s
Switches conforming to standard IEC 947-5-1 section 3	☉			-	
Temperature range	- 20...+ 60°C				
Degree of protection (conforming to IEC 60529)	IP66				
Rated operational characteristics (conforming to EN IEC 60947-5-1)	AC15; B300 (Ue = 240 V, Ie = 1.5 A)/DC13; R300 (Ue = 250 V, Ie = 0.1 A)				
Short-circuit protection	By 6 A cartridge fuse type gG (gl)				
Cable entry	3 tapped entries for ISO M20 cable gland (1)				
Fixing centres	41 mm				
Body dimensions, W x D x H	63 x 30 x 64 mm				
References	2NC+1NO snap action	XCKM3910H29EX	XCKM3902H29EX	XCKM3921H29EX	XCKM3915H29EX XCKM3906H29EX

(1) 2 entries fitted with blanking plugs, 1 entry fitted with ISO M20 cable gland

Application - hoisting, handling, conveying



Limit switch type	XCKMR metal, 3 cable entries	
With head for movement	Rotary (lever)	
Conformity	Directive ATEX 94/9/EC, EN/IEC 60079-0, EN/IEC 60079-31	
Zone D (dust)	21 - 22	
EC type examination certificate number / marking	INERIS 04ATEX0014X / II 2 D-Ex tb III C T85°C Db IP66/67	
Type of operator	Metal rod levers, "crossed"	Metal rod levers, "crossed" reversed head
Mechanical durability (millions of operating cycles)	2	
Actuation speed	1.5 m/s	
Switches conforming to standard IEC 947-5-1 section 3	☉	
Temperature range	- 20...+ 60°C	
Degree of protection (conforming to IEC 60529)	IP66	
Rated operational characteristics (conforming to EN IEC 60947-5-1)	AC15; A300 (Ue = 240 V, Ie = 3 A)/DC13; Q300 (Ue = 125 V, Ie = 0.55 A)	
Short-circuit protection	By 10 A cartridge fuse type gG (gl)	
Cable entry	3 tapped entries for ISO M20 cable gland (1)	
Fixing centres	61.5 mm	
Body dimensions, W x D x H	118 x 59 x 77 mm	
2 (NC+NC) staggered, slow break contacts	XCKMR54D1H29EX	XCKMR54D2H29EX
2 (NC+NO) snap action contacts, both actuated in each direction	-	
2 (NC+NO) snap action contacts, 1 actuated in each direction	-	
2 CO staggered snap action contacts	-	

(1) 2 entries fitted with blanking plugs, 1 entry fitted with ISO M20 cable gland

Other characteristics: please refer to the "Detection for OsiSense automation solutions" catalog.

Other versions: please consult our Customer Care Centre.



XCKJ metal, fixed body, conforming to standard EN 50041
Linear (plunger) | Rotary (lever)

Directive ATEX 94/9/EC, EN/IEC 60079-0, EN/IEC 60079-31

21 - 22

INERIS 04ATEX0014X / II2 D-Ex tb III C T85°C Db IP66/67

Metal end plunger	Steel roller plunger	Steel roller lever	Thermoplastic roller lever	Variable length thermoplastic roller lever	Polyamide rod lever, Ø 6 x 200 mm
30	25	30		20	
0.5 m/s	1 m/s	1.5 m/s			
⊖				-	
- 20...+ 60°C					
IP66					
AC15; B300 (Ue = 240 V, Ie = 1.5 A)/DC13; R300 (Ue = 250 V, Ie = 0.1 A)					
By 6 A cartridge fuse type gG (gl)					
1 entry fitted with ISO M20 cable gland					
30 x 60 mm					
40 x 44 x 77 mm					
XCKJ3961H29EX	XCKJ3967H29EX	XCKJ390513H29EX	XCKJ390511H29EX	XCKJ390541H29EX	XCKJ390559H29EX

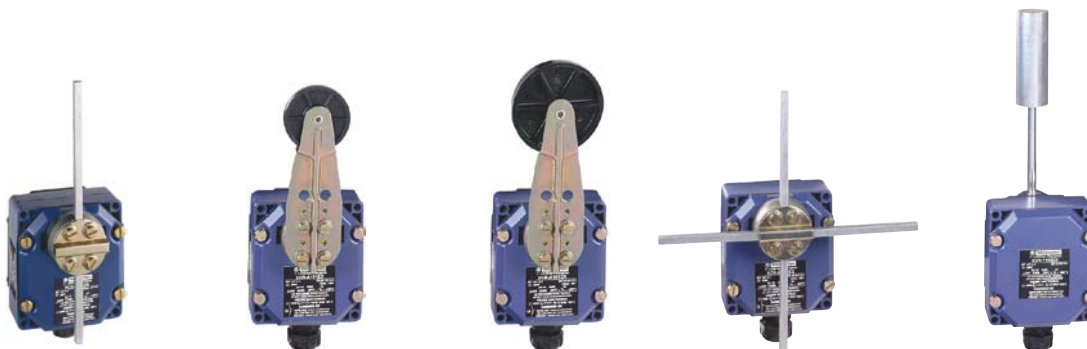

XCR metal
Rotary (lever)

Conveyor belt shift monitoring switches

Directive ATEX 94/9/EC, EN/IEC 60079-0, EN/IEC 60079-31

21 - 22

INERIS 04ATEX0024X / II2 D-Ex tb III C T85°C Db IP66

Square (6 mm) rod lever, spring return to off position	Thermoplastic roller (Ø 30 mm) lever, spring return to off position	Large thermoplastic roller (Ø 50 mm) lever, spring return to off position	Metal rod levers, "crossed", stay put	Galvanised steel operating lever	Stainless steel operating lever
10				0.3	
1.5 m/s					
⊖				-	
- 20...+ 60°C					
IP65					
AC15; A300 (Ue = 240 V, Ie = 3 A)/DC13; Q300 (Ue = 250 V, Ie = 0.27 A)					
By 10 A cartridge fuse type gG (gl)					
1 entry fitted with n° 13 cable gland					
85 x 75 mm					
85 x 75 x 95 mm					
-					
XCRA111EX	XCRA121EX	XCRA151EX	XCRE181EX (2)	-	
XCRB111EX	XCRB121EX	XCRB151EX	XCRF171EX (3)	-	
-				XCRT115EX	XCRT215EX

(2) "Crossed" rods (3) "T" rods



OsiSense XM

Electromechanical pressure & vacuum switches

Adjustable differential, regulation between 2 thresholds



Type		Vacuum switches and vacu-pressure switches with setting scale		
Size		- 1 bar	- 0.2 bar	5 bar
Conformity		Directive ATEX 94/9/EC, EN/IEC 60079-0, EN/IEC 60079-31		
Zone D (dust)		21 - 22		
EC type examination certificate number / marking		INERIS 04ATEX0058 / II2 D-Ex tb III C T85°C Db IP66		
Fluid connection		1/4" BSP female		
Electrical connection		Screw terminals, 1 entry fitted with ISO M20 cable gland		
Temperature range		- 20...+ 60°C		
Degree of protection		IP66		
Rated operational characteristics (conforming to EN IEC 60947-5-1)		AC15; B300 (Ue = 240 V, Ie = 1.5 A; Ue = 120 V, Ie = 3 A)/DC13; R300 (Ue = 250 V, Ie = 0.1 A)		
Short-circuit protection		By 10 A cartridge fuse type gG (gl)		
Setting range of upper limit (PH)		-0.14...-1 bar	-0.02...-0.2 bar	-0.5...5 bar
Body dimensions, W x D x H		55 x 77.5 x 158 mm	150 x 155.5 x 145 mm	113 x 35 x 75 mm
Fluids controlled		Oil, water, air, up to +70°C		
Possible differential (subtract from PH to give PB) (1)	Min. at low setting	0.13 bar	0.018 bar	0.5 bar
	Min. at high setting	0.13 bar	0.018 bar	0.5 bar
	Max. at high setting	0.8 bar	0.18 bar	6 bar
1 CO single pole, snap action contact		XMLBM02V2S12EX	XMLBM03R2S12EX	XMLBM05A2S12EX

(1) For XMLBM02V2S12EX and XMLBM03R2S12EX vacuum switches add to PB to give PH



Type		Pressure switches with setting scale		
Size		10 bar	20 bar	35 bar
Conformity		Directive ATEX 94/9/EC, EN/IEC 60079-0, EN/IEC 60079-31		
Zone D (dust)		21 - 22		
EC type examination certificate number / marking		INERIS 04ATEX0058 / II2 D-Ex tb III C T85°C Db IP66		
Fluid connection		1/4" BSP female		
Electrical connection		Screw terminals, 1 entry fitted with ISO M20 cable gland		
Temperature range		- 20...+ 60°C		
Degree of protection		IP66		
Rated operational characteristics (conforming to EN IEC 60947-5-1)		AC15; B300 (Ue = 240 V, Ie = 1.5 A; Ue = 120 V, Ie = 3 A)/DC13; R300 (Ue = 250 V, Ie = 0.1 A)		
Short-circuit protection		By 10 A cartridge fuse type gG (gl)		
Setting range of upper limit (PH)		0.7...10 bar	1.3...20 bar	3.5...35 bar
Body dimensions, W x D x H		35 x 75 x 113 mm		
Fluids controlled		Oil, water, air, up to +70°C		
Possible differential (subtract from PH to give PB)	Min. at low setting	0.57 bar	1 bar	1.7 bar
	Min. at high setting	0.85 bar	1.6 bar	2.55 bar
	Max. at high setting	7.5 bar	11 bar	20 bar
1 CO single pole, snap action contact		XMLB010A2S12EX	XMLB020A2S12EX	XMLB035A2S12EX

Other characteristics: please refer to the "Detection for OsiSense automation solutions" catalog.



Pressure switches with setting scale				
0.05 bar	0.35 bar	1 bar	2.5 bar	4 bar
Directive ATEX 94/9/EC, EN/IEC 60079-0, EN/IEC 60079-31				
21 - 22				
INERIS 04ATEX0058 / II2 D-Ex tb III C T85°C Db IP66				
1/4" BSP female				
Screw terminals, 1 entry fitted with ISO M20 cable gland				
- 20...+ 60°C				
IP66				
AC15; B300 (Ue = 240 V, Ie = 1.5 A; Ue = 120 V, Ie = 3 A)/DC13; R300 (Ue = 250 V, Ie = 0.1 A)				
By 10 A cartridge fuse type gG (gl)				
0.026...0.05 bar	0.045...0.35 bar	0.05...1 bar	0.3...2.5 bar	0.25...4 bar
200 x 204 x 145 mm	110 x 110 x 162 mm		55 x 77.5 x 158 mm	55 x 77.5 x 158 mm
Oil, air, up to +160°C			Oil, water, air, up to +70°C	
0.0014 bar	0.042 bar	0.04 bar	0.16 bar	0.2 bar
0.004 bar	0.05 bar	0.06 bar	0.21 bar	0.25 bar
0.04 bar	0.3 bar	0.75 bar	1.75 bar	2.4 bar
XMLBL05R2S12EX	XMLBL35R2S12EX	XMLB001R2S12EX	XMLB002A2S12EX	XMLB004A2S12EX

(1) For XMLBM02V2S12EX and XMLBM03R2S12EX vacuum switches add to PB to give PH



Pressure switches with setting scale			
70 bar	160 bar	300 bar	500 bar
Directive ATEX 94/9/EC, EN/IEC 60079-0, EN/IEC 60079-31			
21 - 22			
INERIS 04ATEX0058 / II2 D-Ex tb III C T85°C Db IP66			
1/4" BSP female			
Screw terminals, 1 entry fitted with ISO M20 cable gland			
- 20...+ 60°C			
IP66			
AC15; B300 (Ue = 240 V, Ie = 1.5 A; Ue = 120 V, Ie = 3 A)/DC13; R300 (Ue = 250 V, Ie = 0.1 A)			
By 10 A cartridge fuse type gG (gl)			
7...70 bar	10...160 bar	22...300 bar	30...500 bar
35 x 75 x 113 mm			
Oil, up to +160°C			
4.7 bar	9.3 bar	19.4 bar	23 bar
8.8 bar	20.8 bar	37 bar	52.6 bar
50 bar	100 bar	200 bar	300 bar
XMLB070D2S12EX	XMLB160D2S12EX	XMLB300D2S12EX	XMLB500D2S12EX



OsiSense XS

Inductive proximity sensors

Discrete, metal case



Sensor type	3-wire DC PNP, flush mountable in metal			
Conformity	Directive ATEX 94/9/EC, EN 60079-0, EN 60079-31			
Zone D (dust)	21 - 22			
EC type examination certificate number / marking	INERIS 04ATEX0022X / II2 D-Ex tb III C T90°C Db IP68			
Nominal sensing distance Sn	4 mm	8 mm	15 mm	
Operating zone	0...3.2 mm	0...6.4 mm	0...12 mm	
Temperature range	- 20...+ 60°C			
Degree of protection (conforming to IEC 60529)	IP68			
Connection	Pre-cabled, PvR, L = 10 m			
Dimensions	M12 x 50 mm	M18 x 60 mm	M30 x 60 mm	
Supply voltage (including ripple)	10...58 VDC			
Maximum switching capacity	200 mA			
Overload and short-circuit protection	Yes			
LED output state indicator	Yes			
Voltage drop, closed state, at I nominal	≤ 2 V			
Switching frequency	2500 Hz	1000 Hz	500 Hz	
References	NO function	XS612B1PAL10EX	XS618B1PAL10EX	XS630B1PAL10EX
	NC function	XS612B1PBL10EX	XS618B1PBL10EX	XS630B1PBL10EX

Analog, metal case



Sensor type	Analogue, 2-wire AC/DC, flush mountable in metal			
Conformity	Directive ATEX 94/9/EC, EN 60079-0, EN 60079-31			
Zone D (dust)	21 - 22			
EC type examination certificate number / marking	INERIS 04ATEX0022X / II2 D-Ex tb III C T90°C Db IP67			
Nominal sensing distance Sn	2 mm	5 mm	10 mm	
Operating zone	0.2...2 mm	0.5...5 mm	1...10 mm	
Temperature range	- 20...+ 60°C			
Degree of protection (conforming to IEC 60529)	IP67			
Connection	Pre-cabled, PvR, L = 2 m			
Dimensions	M12 x 50 mm	M18 x 60 mm	M30 x 60 mm	
Supply voltage (including ripple)	10...38 VAC/DC			
Linearity error	10%			
Operating frequency	1500 Hz	500 Hz	300 Hz	
References	4...20 mA output	XS1M12AB120EX	XS1M18AB120EX	XS1M30AB120EX

Inductive Proximity sensors

Rotation monitoring, metal case



M30

Sensor type	3-wire DC PNP, flush mountable in metal	
Conformity	Directive ATEX 94/9/EC, EN 60079-0, EN 60079-31	
Zone D (dust)	21 - 22	
EC type examination certificate number / marking	INERIS 04ATEX0022X /  II2 D-Ex tb III C T90°C Db IP67	
Nominal sensing distance Sn	10 mm	
Operating zone	0...8 mm	
Temperature range	- 20...+ 60°C	
Degree of protection (conforming to IEC 60529)	IP67	
Connection	Pre-cabled, PvR, L = 2 m	
Dimensions	M30 x 81 mm	
Supply voltage (including ripple)	10...58 VDC	
Maximum switching capacity	200 mA	
Overload and short-circuit protection	Yes	
LED output state indicator	Yes	
Voltage drop, closed state, at I nominal	≤ 2 V	
Version	Slow	Fast
Maximum speed of passing object	6000 impulses/minute	48,000 impulses/minute
Adjustable frequency range	6...150 impulses/minute	120...3000 impulses/minute
References	NC function	
	XSAV11373EX	XSAV12373EX



OsiSense XS

Namur inductive sensors

Metal or plastic case



Sensor type	2-wire DC, flush mountable in metal					
Case type	Metal			Plastic		
Conformity	Directive ATEX 94/9/EC, EN/IEC 60079-0, EN/IEC 60079-11					
Zone D (dust)	20 (to be used in conjunction with intrinsically safe enclosures, see page 5)					
EC type examination certificate number / marking	INERIS 04ATEX0016X / II 1 D-Ex ia III C T85°C Da IP66/67					
Nominal sensing distance Sn	0.8 mm	1.5 mm	2 mm	5 mm	10 mm	
Operating zone	0...0.6 mm	0...0.8 mm	0...1.2 mm	0...1.6 mm	0...4 mm	0...8 mm
Temperature range	- 20...+ 60°C					
Degree of protection (conforming to IEC 60529)	IP67					
Connection	Pre-cabled, PvR, L = 2 m					
Dimensions	M5 x 30 mm	M8 x 26.5 mm	M12 x 38.5 mm	M18 x 41 mm	M30 x 43.5 mm	
Supply voltage (including ripple)	7...12 VDC					
Maximum switching capacity	≤ 1 mA					
Overload and short-circuit protection	Yes					
Residual current, open state	≥ 3 mA					
Switching frequency	1500 Hz		1000 Hz	800 Hz	500 Hz	300 Hz
References	NC function	XSMN08122EX	XSAN01122EX	XSPN01122EX	XSPN02122EX	XSPN05122EX
				XSPN10122EX		

Plastic case



Sensor type	2-wire DC, non flush mountable in metal			
Case type	Plastic			
Conformity	Directive ATEX 94/9/EC, EN/IEC 60079-0, EN/IEC 60079-11			
Zone D (dust)	20			
EC type examination certificate number / marking	INERIS 04ATEX0016X / II 1 D-Ex ia III C T85°C Da IP66/67			
Nominal sensing distance Sn	4 mm	8 mm	15 mm	40 mm
Operating zone	0...3.2 mm	0...6.4 mm	0...12 mm	0...32 mm
Temperature range	- 20...+ 60°C			
Degree of protection (conforming to IEC 60529)	IP67			
Connection	Pre-cabled, PvR, L = 2 m			
Dimensions	M12 x 38.5 mm	M18 x 41 mm	M30 x 43.5 mm	100 x 80 x 40 mm
Supply voltage (including ripple)	7...12 VDC			
Maximum switching capacity	≤ 1 mA			
Overload and short-circuit protection	Yes			
LED output state indicator	Yes			
Residual current, open state	≥ 3 mA			
Switching frequency	400 Hz	300 Hz	200 Hz	25 Hz
References	NC function	XSPN08122EX	XSPN15122EX	XSDN401229EX
		XSPN04122EX		

(1) Flush mountable in metal



Intrinsically safe module

Processing module



Module type		Discrete					
		Inputs		Relay inputs/outputs			
Conformity		Directive ATEX 94/9/EC, EN 60079-0, EN 60079-11, EN 61241-11					
Zone D (dust)		Mounted outside zone (to be used in conjunction with products for zone 20, 21 or 22)					
EC type examination certificate number / marking		LCIE 00ATEX6034X / II(1) GD-[Ex ia Ga] IIC / [Ex ia Da] III C					
Zone 20	Number of input channels	2	4	2	2		
	Number of output channels	–		1	1		
	Type of output channel, load excitation	–		Low consumption solenoid valve, < 7 mA – with hysteresis	High consumption solenoid valve, < 40 mA – with hysteresis		
Outside zone	Number of recopying channels	2	4	2	2		
	Switching voltage	5...230 VAC; 5...24 VDC					
	Switching current	10 mA...0.5 A (AC); 10 mA...0.5 A, L/R 48 ms (DC)					
Temperature range		– 20...+ 60°C					
Connection		Removable screw terminal blocks					
Mounting		On 35 mm DIN rail					
Dimensions, W x D x H		29.5 x 120 x 90 mm					
Supply voltage (including ripple)		24 VDC (0.95...1.1 Un)					
Consumption		5 W					
References		NY320N2RB1	NY340N4RB1	NY321L2RB1	NY321L1RB1	NY321H2RB1	NY321H1RB1



Module type		Discrete			
		Load excitation outputs			
Conformity		Directive ATEX 94/9/EC, EN 60079-0, EN 60079-11, EN 61241-11			
Zone D (dust)		Mounted outside zone (to be used in conjunction with products for zone 20, 21 or 22)			
EC type examination certificate number / marking		LCIE 00ATEX6034X / II(1) GD-[Ex ia Ga] IIC / [Ex ia Da] III C			
Zone 20	Number of load excitation channels	2		4	
	Maximum current	< 7 mA	< 40 mA	< 7 mA	< 40 mA
Outside zone	Control voltage	24 VDC ± 10%			
	Control current	State 1 = 6.5 < I < 9 mA and 21.6 < U < 26.4 V; State 0 = I ≤ 0.4 mA and U ≤ 1.2 V			
Temperature range		– 20...+ 60°C			
Connection		Removable screw terminal blocks			
Mounting		On 35 mm DIN rail			
Dimensions, W x D x H		29.5 x 120 x 90 mm			
Supply voltage (including ripple)		24 VDC (0.95...1.1 Un)			
Consumption		5 W			
References		NY302L0NB1	NY302H0NB1	NY304L0NB1	NY304H0NB1



Preventa

Safety switches and actuators

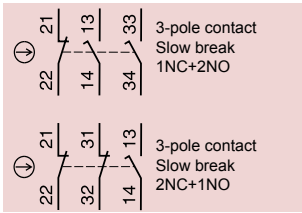

ISO entry (to EN 50262)



Position of the contact when the actuator is in the head of the switch

Metal switches type	XCSA/B/C, 1 entry fitted with ISO M20 cable gland		
With head	Without locking	Interlocking, unlocking by button	Interlocking, unlocking by key lock
Conformity	Directive ATEX 94/9/CE, EN/IEC 60079-0, EN/IEC 60079-31		
Zone D (dust)	21 - 22		
EC type examination certificate number / marking	INERIS 04ATEX0014X / II2 D-Ex tb III C T85°C Db IP67		
Maximum safety level (1)	PL=e, category 4 conforming to EN/ISO 13849-1 and SIL CL3 conforming to EN/IEC 62061		
Actuation speed (min → max)	0,1 m/s → 0,5 m/s		
Degree of protection	IP 67		
Rated operational characteristics (conforming to EN IEC 60947-5-1)	AC 15, A 300 / DC 13, Q 300		
Temperature range	-20...+60°C		
Dimensions (body+head) W x D x H	40 x 44 x 113.5 mm	52 x 44 x 113.5 mm	52 x 44 x 113.5 mm
Short-circuit protection	By 10 A cartridge fuse type gG (gl)		
Reliability data B10d	5 000 000 (value given for a service life of 20 years, limited by mechanical or contact wear)		
Complete switch	1NC+2NO	XCSA502EX →	XCSB502EX →
	2NC+1NO	XCSA702EX →	XCSB702EX →
			XCSC702EX →

Accessories

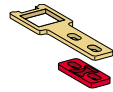

Straight actuator



Wide actuator

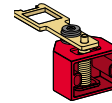

Pivoting actuator

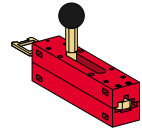

Door lock

For safety switches XCSA/B/C	Actuators			Door lock
References	XCSZ01	XCSZ02	XCSZ03	XCSZ05

Coded magnetic

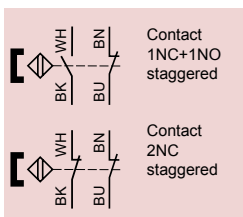

Contact states shown are whilst the magnet is in front of the switch



Plastic switches type	XCSDM coded magnetic, Pre-cabled, L = 2 m		
	Rectangular without LED		
Conformity	Directive Atex 94/9/CE, EN 60079-0, EN 60079-18, EN 60079-31, EN 1088, EN/ISO 13849-1		
Zone D (dust)	0-1-2/20-21-22*(according to protection mode, mD or ia).		
EC type examination certificate number / marking	INERIS 04ATEX0036 / II1 D-Ex ia III B Da T135°C / II2 D-Ex tb III C T135°C Db IP67		
Maximum safety level (1)	PL=e, category 4 conforming to EN/ISO 13849-1 and SIL CL3 conforming to EN/IEC 62061		
Switches for actuation	Face to face, face to side, side to side		
Degree of protection	IP 66 + IP 67		
Type of contact	REED		
Rated operational characteristics (conforming to EN IEC 60947-5-1)	Ue = 24 VDC, Ie = 100 mA		
Temperature range	-20...+60°C		
Dimensions W x D x H	16 x 7 x 51 mm		
Operating zone	Sao = 5 / Sar = 15		
Short-circuit protection	By 10 A cartridge fuse type gG (gl)		
Reliability data B10d	50 000 000 (value given for a service life of 20 years, limited by mechanical or contact wear)		
Switch with coded magnet	1NC+1NO staggered	XCSDMC5902EX	
	2NC staggered	XCSDMC7902EX	

(1) Using an appropriate and correctly connected control system.



Preventa

Emergency stops

Emergency stop rope pull switches



For operating cable up to 70 m long	Latching, without indicator light				
Conformity	Directive ATEX 94/9/EC, EN/IEC 60079-0, EN/IEC 60079-31				
Zone D (dust)	21 - 22				
EC type examination certificate number / marking	INERIS 04ATEX0015 / II 2 D-Ex tb III C T85°C Db IP65				
Maximum safety level (1)	PL=e, category 4 conforming to EN/ISO 13849-1 and SIL CL3 conforming to EN/IEC 62061				
Mechanical durability (millions of operating cycles)	0.01				
Temperature range	- 20...+ 60°C				
Degree of protection	IP65				
Connection	2 entries fitted with blanking plugs, 1 entry fitted with ISO M20 cable gland				
Rated operational characteristics (conforming to EN IEC 60947-5-1)	AC15; A300 (Ue = 240 V, Ie = 3A)/DC13; Q300 (Ue = 250 V, Ie = 0.27 A)				
Short-circuit protection	By 10 A cartridge fuse type gG (gl)				
Dimensions, W x D x H	229 x 82 x 142 mm		229 x 105 x 142 mm		
Reset	By booted pushbutton		By key release pushbutton (key n° 421)		
Operating cable length	≤ 70 m		≤ 70 m		
Operating cable anchoring point	To left	To right	To left	To right	
Reliability data B10d	50 000 (value given for a service life of 20 years, limited by mechanical or contact wear)				
References	NC+NO slow break	XY2CE2A250EX	XY2CE1A250EX	XY2CE2A450EX	XY2CE1A450EX
	NC+NC slow break	XY2CE2A270EX	XY2CE1A270EX	XY2CE2A470EX	XY2CE1A470EX

(1) Using an appropriate and correctly connected control system.

Schneider Electric Industries SAS

Head Office
35, rue Joseph Monier - CS 30323
F92500 Rueil-Malmaison Cedex
France

www.tesensors.com

The information provided in this documentation contains general descriptions and/or technical characteristics of the performance of the products contained herein. This documentation is not intended as a substitute for and is not to be used for determining suitability or reliability of these products for specific user applications. It is the duty of any such user or integrator to perform the appropriate and complete risk analysis, evaluation and testing of the products with respect to the relevant specific application or use thereof. Neither Schneider Electric nor any of its affiliates or subsidiaries shall be responsible or liable for misuse of the information contained herein.

Design : IGS-CP
Photos : Schneider Electric
Print :